

COLOR STRIKE M

User Manual



Model ID: COLORSTRIKEM

Edition Notes

The Color STRIKE M User Manual includes a description, safety precautions, installation, programming, operation and maintenance instructions for the Color STRIKE M as of the release date of this edition.

Trademarks

Chauvet, Chauvet Professional, the Chauvet logo and Strike are registered trademarks or trademarks of Chauvet & Sons, LLC (d/b/a Chauvet and Chauvet Lighting) in the United States and other countries. Other company and product names and logos referred to herein may be trademarks of their respective companies.

Copyright Notice

The works of authorship contained in this manual, including, but not limited to, all design, text and images are owned by Chauvet.

© **Copyright 2023 Chauvet & Sons, LLC. All rights reserved.**

Electronically published by Chauvet in the United States of America.

Manual Use

Chauvet authorizes its customers to download and print this manual for professional information purposes only. Chauvet expressly prohibits the usage, copy, storage, distribution, modification, or printing of this manual or its content for any other purpose without written consent from Chauvet.

Document Printing

For best results, print this document in color, on letter size paper (8.5 x 11 in), double-sided. If using A4 paper (210 x 297 mm), configure the printer to scale the content accordingly.

Intended Audience

Any person installing, operating, and/or maintaining this product should completely read through the guide that shipped with the product, as well as this manual, before installing, operating, or maintaining this product.

Disclaimer

Chauvet believes that the information contained in this manual is accurate in all respects. However, Chauvet assumes no responsibility and specifically disclaims any and all liability to any party for any loss, damage or disruption caused by any errors or omissions in this document, whether such errors or omissions result from negligence, accident or any other cause. Chauvet reserves the right to revise the content of this document without any obligation to notify any person or company of such revision, however, Chauvet has no obligation to make, and does not commit to make, any such revisions. Download the latest version from www.chauvetprofessional.com.

Document Revision

This Color STRIKE M User Manual is the 8th edition of this document. Go to www.chauvetprofessional.com for the latest version.

TABLE OF CONTENTS

1. Before You Begin	1
What Is Included	1
Claims	1
Text Conventions	1
Symbols	1
FCC Statement of Compliance	2
RF Exposure Warning for North America and Australia	2
Safety Notes.....	3
Personal Safety.....	3
Mounting and Rigging	3
Power and Wiring.....	3
Operation	3
Expected LED Lifespan.....	3
2. Introduction	4
Features.....	4
Product Overview.....	4
Product Dimensions.....	5
3. Setup	6
AC Power	6
AC Plug	6
Remote Device Management.....	6
USB Software Update	6
Mounting	7
Orientation.....	7
Rigging	7
Procedure.....	7
Product Mounting Diagram.....	7
4. Operation	8
Control Panel Description	8
Programming.....	8
Passcode	8
Configuration (DMX)	8
Control Personalities	8
Starting Address.....	8
Menu Map	9
Control Channel Assignments and Values.....	12
97CH	12
74CH	17
47CH.....	19
30CH.....	21
24CH.....	25
13CH.....	28
11CH.....	30
8CH.....	30
Pixel Mapping.....	31
Plate Patterns.....	32
Beam Patterns	33
Configuration.....	34
Static Color.....	34

Plate FX	34
Beam Intensity	34
Beam Flash Duration	34
Beam Flash Rate	34
Tilt	34
Tilt Offset	34
Tilt Invert	35
Pixel Invert	35
LED Array Swap.....	35
Master Slave	35
Dimmer Mode.....	35
White Balance	35
Pulse Width Modulation	35
Display Invert	35
Display Back Light.....	36
Key Lock	36
Product Information	36
Factory Reset.....	36
5. Maintenance.....	37
Product Maintenance	37
6. Technical Specifications	38
Contact Us	39

Before You Begin

1. Before You Begin

What Is Included

- Color STRIKE M
- Seetronic Powerkon IP65 power cable
- Omega bracket with mounting hardware
- Quick Reference Guide

Claims

Carefully unpack the product immediately and check the container to make sure all the parts are in the package and are in good condition.



If the box or the contents (the product and included accessories) appear damaged from shipping, or show signs of mishandling, notify the carrier immediately, not Chauvet. Failure to report damage to the carrier immediately may invalidate your claim. In addition, keep the box and contents for inspection.

For other issues, such as missing components or parts, damage not related to shipping, or concealed damage, file a claim with Chauvet within 7 days of delivery.

Text Conventions

Convention	Meaning
1–512	A range of values
50/60	A set of values of which only one can be chosen
Settings	A menu option not to be modified
<ENTER>	A key to be pressed on the product's control panel

Symbols

Symbol	Meaning
	Critical installation, configuration, or operation information. Not following these instructions may make the product not work, cause damage to the product, or cause harm to the operator.
	Important installation or configuration information. The product may not function correctly if this information is not used.
	Useful information.



Any reference to data or power connections in this manual assumes the use of Seetronic IP-rated cables.



The term “DMX” used throughout this manual refers to the USITT DMX512-A digital data transmission protocol.

FCC Statement of Compliance

This device complies with Part 15 Part B of the FCC rules. Operation is subject to the following two conditions:

1. This device may not cause harmful interference, and
2. This device must accept any interference received, including interference that may cause undesired operation.

This equipment has been tested and found to comply with the limits for a Class B digital device, pursuant to Part 15 of the FCC Rules. These limits are designed to provide reasonable protection against harmful interference in a residential installation. This equipment generates uses and can radiate radio frequency energy and, if not installed and used in accordance with the instructions, may cause harmful interference to radio communications. However, there is no guarantee that interference will not occur in a particular installation. If this equipment does cause harmful interference to radio or television reception, which can be determined by turning the equipment off and on, the user is encouraged to try to correct the interference by one or more of the following measures:

- Reorient or relocate the receiving antenna.
- Increase the separation between the equipment and receiver.
- Connect the equipment into an outlet on a circuit different from that to which the receiver is connected.
- Consult the dealer or an experienced radio/TV technician for help.

Any changes or modifications not expressly approved by the party responsible for compliance could void the user's authority to operate the equipment.

RF Exposure Warning for North America and Australia

Warning! This equipment complies with FCC radiation exposure limits set forth for an uncontrolled environment. This equipment should be installed and operated with a minimum distance of 20 cm between the radiator and your body. This transmitter must not be co-located or operating in conjunction with any other antenna or transmitter.

Before You Begin

Safety Notes

Read all the following safety notes before working with this product. These notes contain important information about the installation, usage, and maintenance of this product.



This product contains no user-serviceable parts. Any reference to servicing in this User Manual will only apply to properly trained, certified technicians. Do not open the housing or attempt any repairs.



All applicable local codes and regulations apply to proper installation of this product.

Personal Safety

- Avoid direct eye exposure to the light source while the product is on.
- Always disconnect the product from the power source before cleaning or replacing the fuse.
- Always connect the product to a grounded circuit to avoid the risk of electrocution.
- Do not touch the product's housing when operating because it may be very hot.

Mounting and Rigging

- Do not submerge this product (IP65). Temporary outdoor operation is fine.
- When using this product in an outdoor environment, use IP65 (or higher) rated power and data cables. Secure unused power and data ports with attached IP65 covers.
- CAUTION: When transferring product from extreme temperature environments, (e.g., cold truck to warm, humid ballroom) condensation may form on the internal electronics of the product. To avoid causing a failure, allow product to fully acclimate to the surrounding environment before connecting it to power.
- Not for permanent outdoor installation in locations with extreme environmental conditions. This includes, but is not limited to:
 - Exposure to a marine/saline environment (within 3 miles of a saltwater body of water).
 - Locations where the normal high or low temperatures exceed the temperature ranges in this manual.
 - Locations that are prone to flooding or being buried in snow.
 - Areas where the product will be subjected to extreme radiation or caustic substances.
- Mount this product in a location with adequate ventilation, at least 20 in (50 cm) from adjacent surfaces.
- Make sure there are no flammable materials close to the product when operating.
- When hanging this product, always secure to a fastening device using a safety cable.

Power and Wiring

- Make sure the power cord is not crimped or damaged.
- Always make sure you are connecting this product to the proper voltage in accordance with the specifications in this manual or on the product's specification label.
- To eliminate unnecessary wear and improve its lifespan, during periods of non-use completely disconnect the product from power via breaker or by unplugging it.
- Never connect this product to a dimmer pack or rheostat.
- Make sure to replace the fuse with another of the same type and rating.
- Never disconnect this product by pulling or tugging on the power cable.

Operation

- Do not operate this product if there is damage on the housing, lenses, or cables. Have the damaged parts replaced by an authorized technician at once.
- Do not cover the ventilation slots when operating to avoid internal overheating.
- The maximum ambient temperature is 113 °F (45 °C). Do not operate the product at higher temperatures.
- The minimum ambient temperature is -4°F (-20°C). Do not operate the product at lower temperatures.
- In the event of a serious operation problem, stop using this product immediately!



If your Chauvet product requires service, contact Chauvet Technical Support.

Expected LED Lifespan

Over time, use and heat will gradually reduce LED brightness. Clustered LEDs produce more heat than single LEDs, contributing to shorter lifespans if always used at full intensity. The average LED lifespan is 40,000 to 50,000 hours. To extend LED lifespan, maintain proper ventilation around the product, and limit the overall intensity.

2. Introduction

Features

- High-power, 180° tilting hybrid strobe/wash with IP65 rating for all-weather use
- 14 controllable sections of RGB LEDs and 28 sections of control of the white strobe LEDs
- Multiple mounting locations and a yoke that can be repositioned with ¼ turn adapters for creative and convenient rigging options in vertical and horizontal orientations
- Multitude of built-in effect macros with control parameters
- DMX, Art-Net, and sACN control capability
- 16-bit dimming control for smooth, perfect fades
- Easy-to-use OLED display
- Rugged design for years of rough use in the most extreme conditions
- Adjustable Pulse Width Modulation (PWM) and Remote Device Management (RDM) for added flexibility
- USB port for fixture software updates
- Built-in alignment pins to ensure perfectly straight linear arrays

Product Overview

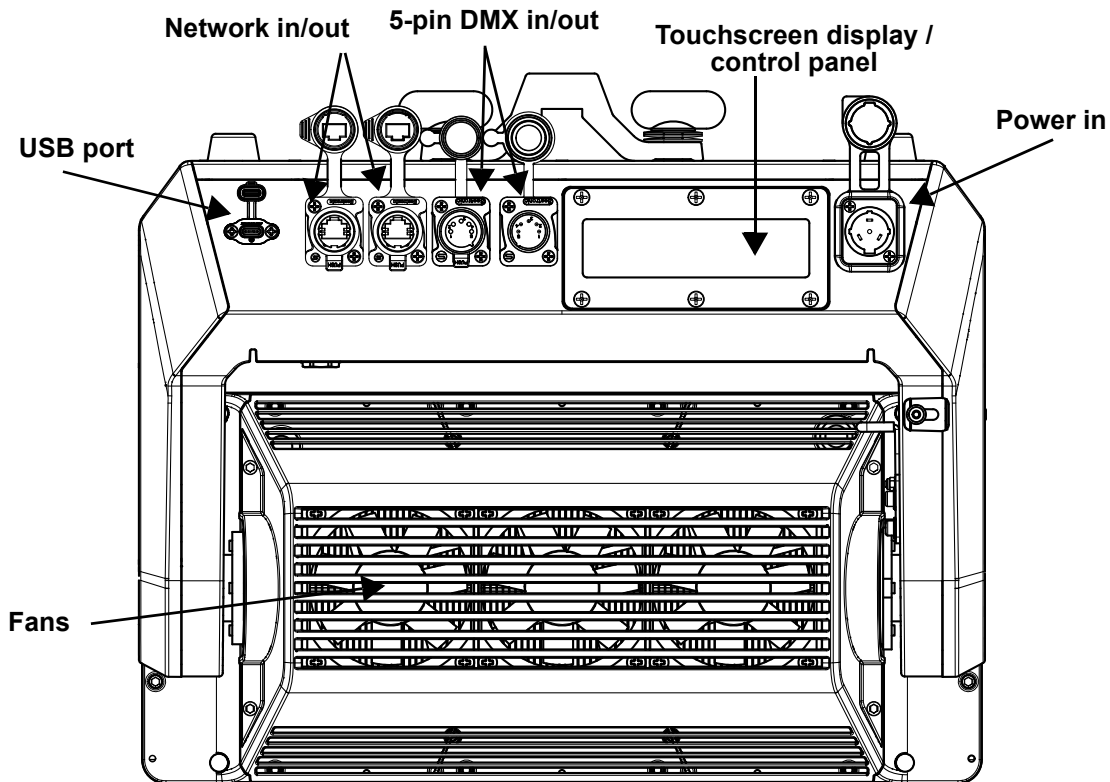

Product Dimensions

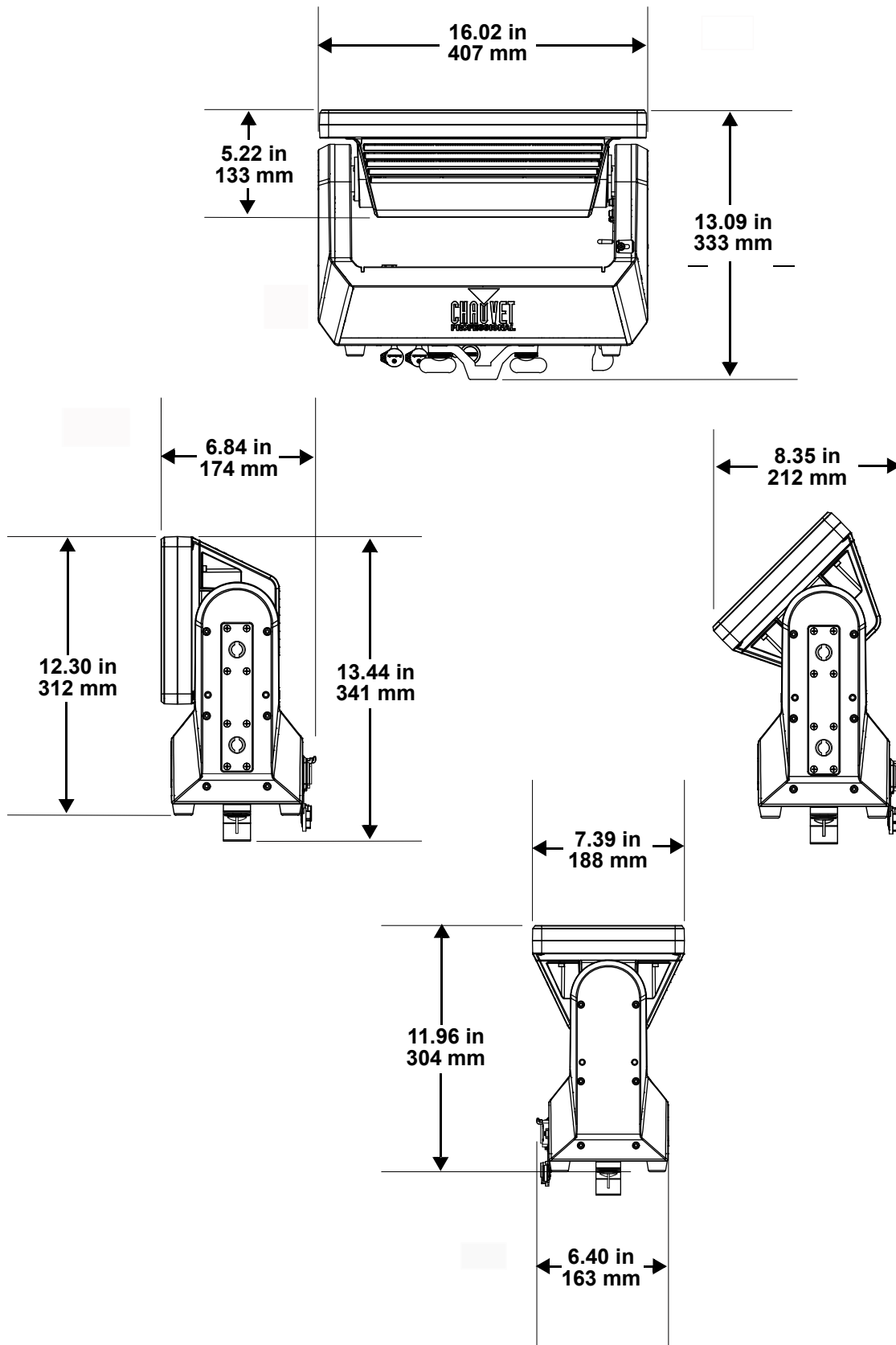

3. Setup

AC Power

The Color STRIKE M has an auto-ranging power supply and it can work with an input voltage range of 100 to 240 VAC, 50/60 Hz.

To determine the product's power requirements (circuit breaker, power outlet, and wiring), use the current value listed on the label affixed to the product's back panel, or refer to the product's specifications chart. The listed current rating indicates the product's average current draw under normal conditions.



- **Always connect the product to a protected circuit (a circuit breaker or fuse). Make sure the product has an appropriate electrical ground to avoid the risk of electrocution or fire.**
- **To eliminate unnecessary wear and improve its lifespan, during periods of non-use completely disconnect the product from power via breaker or by unplugging it.**



Never connect the product to a rheostat (variable resistor) or dimmer circuit, even if the rheostat or dimmer channel serves only as a 0 to 100% switch.

AC Plug

The Color STRIKE M comes with a power input cord terminated with a Seetronic Powerkon IP65 connector on one end and an Edison plug on the other end (U.S. market). If the power input cord that came with your product has no plug, or if you need to change the plug, use the table below to wire the new plug.

Connection	Wire (U.S.)	Wire (Europe)	Screw Color
AC Live	Black	Brown	Yellow or Brass
AC Neutral	White	Blue	Silver
AC Ground	Green/Yellow	Green/Yellow	Green

Remote Device Management

Remote Device Management, or RDM, is a standard for allowing DMX-enabled devices to communicate bi-directionally along existing DMX cabling. Check the DMX controller's User Manual or with the manufacturer as not all DMX controllers have this capability. The Color STRIKE M supports RDM protocol that allows feedback to make changes to menu map options.

USB Software Update

The Color STRIKE M allows for software updates with a USB device using the built-in USB port. To update the software using a USB flash drive, do the following:

1. Power on the product, and plug the flash drive into the USB port.
2. Once the flash drive has been detected, the message "**Upgrade Firmware**" will be displayed. Press **<ENTER>**.
 - If a different message appears on the display, search for the updated software in the Main Menu (**Update Firmware**) and select from **Only This Unit**, **Multiple Units**, or **Other Fixture Type**. A list of the updated software files will be displayed.
3. Select the file that needs to be uploaded. The message "Are you sure?" will be displayed. Press **<ENTER>**.
4. If the selected file is correct, the upgrade will be completed. Restart the product.
 - If the selected file is incorrect, the upgrade will fail, and the display will go back to the main interface. Repeat steps 1-3 using the correct file.



Place the .chl file in the root directory of the USB drive.



The product's USB port supports up to 32GB capacity and only works with FAT32 file format.

Mounting

Before mounting the product, read and follow the safety recommendations indicated in the [Safety Notes](#). For our CHAUVET Professional line of mounting clamps, go to <http://trusst.com/products/>.

Orientation

Always mount this product in a safe position, making sure there is adequate room for ventilation, configuration, and maintenance.

Rigging

Chauvet recommends using the following general guidelines when mounting this product.

- Before deciding on a location for the product, make sure there is easy access to the product for maintenance and programming purposes.
- Make sure that the structure onto which you are mounting the product can support the product's weight. See the [Technical Specifications](#) for weight information.
- When mounting the product overhead, always use a safety cable. Mount the product securely to a rigging point, whether an elevated platform or a truss.
- When rigging the product onto a truss, use a mounting clamp of appropriate weight capacity.

Procedure

The Color STRIKE M comes with a bracket to which you can attach a mounting clamp directly. Mounting clamps are sold separately. Make sure the clamps are capable of supporting the weight of this product. Use at least two mounting points per product. For the CHAUVET Professional line of mounting clamps, go to <http://www.trusst.com/products>.

Product Mounting Diagram

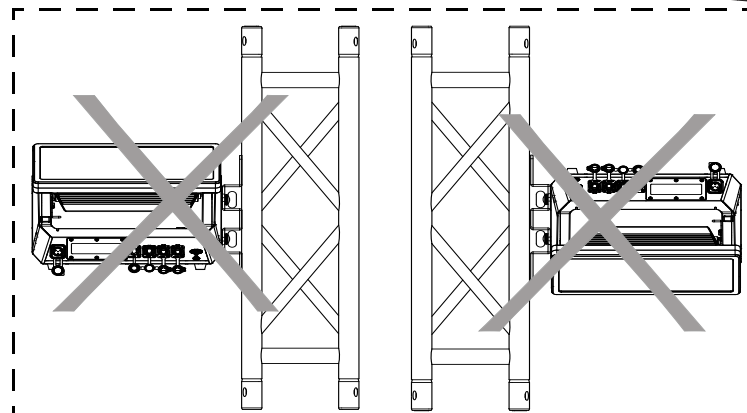
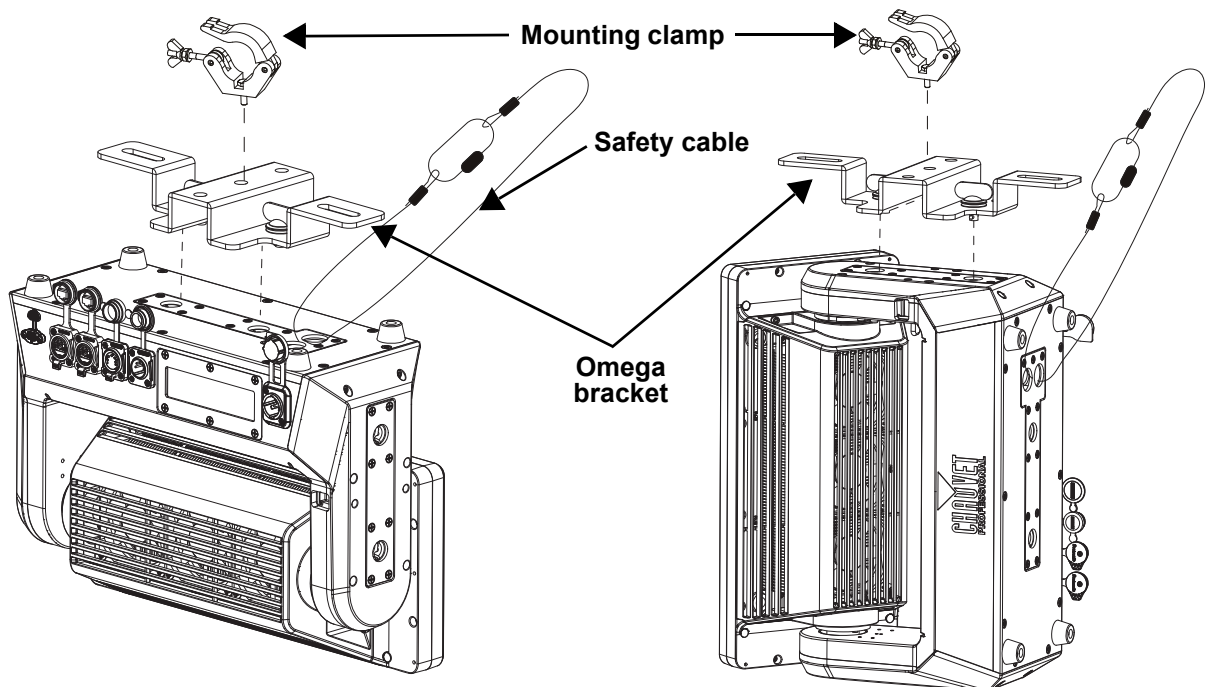

4. Operation

Control Panel Description

Button	Function
<MENU>	Exits from the current menu or function
<UP>	Enables the selected menu or sets the selected value in to the current function
<DOWN>	Navigates upward through the menu list or increases the numeric value when in a function
<ENTER>	Navigates downward through the menu list or decreases the numeric value when in a function

Programming

Refer to the Menu Map to understand the menu options. The menu map shows the main level and a variable number of programming levels for each option.

- To go to the desired main level, press <MENU> repeatedly until the option shows on the display. Press <ENTER> to select. This will take you to the first programming level for that option.
- To select an option or value within the current programming level, press <UP> or <DOWN> until the option shows on the display. Press <ENTER> to select. In this case, if there is another programming level, you will see that first option, or you will see the selected value.
- Press <MENU> repeatedly to exit to the previous main level.

Passcode

After being prompted to enter the passcode, press <UP>, <DOWN>, <UP>, <DOWN>, <ENTER>.

Configuration (DMX)

Use control configurations to operate the product with a DMX controller.

Control Personalities

To set the control personality:

1. Go to the **DMX Channel** main level.
2. Select the desired personality, from **8CH**, **11CH**, **13CH**, **24CH**, **30CH**, **47CH**, **74CH**, and **97CH**.



- See the [Starting Address](#) section for the highest starting address you can select for each personality.
- Make sure that the starting addresses on the various products do not overlap due to the new personality setting.

Starting Address

Each product will respond to a unique starting address from the controller. All products with the same starting address will respond in unison. To set the starting address:

1. Go to the **Start Address** main level.
2. Select the starting address (**1–512**).
 - The highest recommended starting address for **8 Ch** is **505**.
 - The highest recommended starting address for **11 Ch** is **502**.
 - The highest recommended starting address for **13 Ch** is **500**.
 - The highest recommended starting address for **24 Ch** is **489**.
 - The highest recommended starting address for **30 Ch** is **483**.
 - The highest recommended starting address for **47 Ch** is **466**.
 - The highest recommended starting address for **74 Ch** is **439**.
 - The highest recommended starting address for **97 Ch** is **416**.

Operation

Menu Map

Refer to the Color STRIKE M product page on www.chauvetprofessional.com for the latest menu map.

Main Level	Programming Levels			Description
Protocol	DMX512 Art-Net sACN			Sets the control protocol
DMX Address	1–512*			Selects DMX address (*highest channel restricted to personality chosen)
DMX Channel	8CH 11CH 13CH 24CH 30CH 47CH 74CH 97CH			Selects DMX channel
Static	Fixed Color	R G B GB RB RG RGB		Red Green Blue Green + blue Red + blue Red + green Red + green + blue
	Manual Color Mixer	Red Green Blue	0–255	Combines red, green, and blue to make a custom color (0–100%)
Plate FX	Speed	1–100		Adjusts the plate movement speed
		000–255		Adjusts the plate light intensity
	Background Color	R G B GB RB RG RGB		Selects background color
		Off		Turns off background color
	Foreground Color	R G B GB RB RG RGB		Selects foreground color
		Off		Turns off foreground color
Beam Intensity	000–255			Adjusts the beam light intensity
Beam Flash Duration	000–255			Adjusts the duration of the beam flash
Beam Flash Rate	000–255			Adjusts the beam flash rate
Tilt	000–255			Adjusts the tilt range from 0° to 180°

Main Level	Programming Levels			Description
Tilt Offset	000–255			Adjusts the tilt offset range
Tilt Invert	No Yes			Inverts the default tilt orientation
Pixel Invert	Plate1 Invert	No Yes		Inverts the beam and plate pixels individually. Reverts to default setting with a factory reset.
	Plate2 Invert	No Yes		
	Tube1 Invert	No Yes		
	Tube2 Invert	No Yes		
LED Array Swap	Plate Swap	No Yes		Swaps the plate and beam pixel mapping. Keeps the setting even after a factory reset.
	Beam Swap	No Yes		
Master/Slave	Master			DMX mode (master)
	Slave			Slave mode
Dimmer Mode	OFF			Linear dimmer
	DIM1–3			Dimming curves: Dimmer 1 (fast) to Dimmer 3 (slow)
White Balance	Off			Turns white balance off
	Manual	Red Green Blue	125–255	Combines red, green, and blue to create custom color
LED Frequency	600Hz 1200Hz 2000Hz 4000Hz 6000Hz 25000Hz			Sets the Pulse Width Modulation (PWM) frequency
Fan Mode	Auto			Sets fan to auto — fan speed adjusts according to product temperature
	On			Turns fan on
Display Invert	No			Inverts the default display mode
	Yes			
Backlight	10s			Turns off display backlight after 10 seconds of inactivity
	30s			Turns off display backlight after 30 seconds of inactivity
	2Min			Turns off display backlight after 2 minutes of inactivity
	Always On			Display backlight remains on
Key Lock	On			Locks the control panel
	Off			Keeps the control panel unlocked
	Ethernet Setting	Universe	0–255 (ArtNet) 1–255 (sACN)	
IP Address		2.192.0.1		Sets the IP address

Main Level	Programming Levels		Description
Information	Fixture Hours:	___Hours	Displays total hours the product has been powered on
	LED Hours:	__H	Displays the total LED hours
	Disp Ver:	V_._._._._	Displays firmware version
	Drv-Y Ver:	V_._	Displays the tilt PCB version
	LED-A Ver:	V_._	Displays the LED A PCB version
	LED-C Ver:	V_._	Displays the LED C PCB version
	Net Ver:	V_._	Displays the network version
	UID	-----	Displays product UID
Upgrade Firmware	Only This Fixture	-----CHL	Selects an update file for this product, or shows “No such file!”
	Multiple Fixtures	-----CHL	Selects an update file for this and connected Color STRIKE M products, or shows “No such file!”
	Other Fixture Type	-----CHL	Selects an update file for other connected products, or shows “No such file!”
Factory Reset	No		Resets settings to factory default
	Yes		

Control Channel Assignments and Values

97CH

Channel	Function	Value	Percent/Setting
1	Tilt	000 ⇄ 255	0–100%
2	Fine tilt	000 ⇄ 255	0–100%
3	Master dimmer	000 ⇄ 255	0–100%
4	Plate dimmer	000 ⇄ 255	0–100%
5	Beam dimmer	000 ⇄ 255	0–100%
6	Plate flash duration	000 ⇄ 009	Classic shutter mode: disables duration control
		010 ⇄ 250	Slow to fast
		251 ⇄ 255	100% On, no flash/strobe
7	Plate flash rate	000 ⇄ 009	100%
		010 ⇄ 250	Slow to fast
		251 ⇄ 255	100%
8	Beam flash duration	000 ⇄ 009	Classic shutter mode: disables duration control
		010 ⇄ 250	Slow to fast
		251 ⇄ 255	100% On, no flash/strobe
9	Beam flash rate	000 ⇄ 009	100%
		010 ⇄ 250	Slow to fast
		251 ⇄ 255	100% on
10	Plate pixel 1 red	000 ⇄ 255	0–100%
11	Plate pixel 1 green	000 ⇄ 255	0–100%
12	Plate pixel 1 blue	000 ⇄ 255	0–100%
13	Plate pixel 2 red	000 ⇄ 255	0–100%
14	Plate pixel 2 green	000 ⇄ 255	0–100%
15	Plate pixel 2 blue	000 ⇄ 255	0–100%
16	Plate pixel 3 red	000 ⇄ 255	0–100%
17	Plate pixel 3 green	000 ⇄ 255	0–100%
18	Plate pixel 3 blue	000 ⇄ 255	0–100%
19	Plate pixel 4 red	000 ⇄ 255	0–100%
20	Plate pixel 4 green	000 ⇄ 255	0–100%
21	Plate pixel 4 blue	000 ⇄ 255	0–100%
22	Plate pixel 5 red	000 ⇄ 255	0–100%
23	Plate pixel 5 green	000 ⇄ 255	0–100%
24	Plate pixel 5 blue	000 ⇄ 255	0–100%
25	Plate pixel 6 red	000 ⇄ 255	0–100%
26	Plate pixel 6 green	000 ⇄ 255	0–100%
27	Plate pixel 6 blue	000 ⇄ 255	0–100%
28	Plate pixel 7 red	000 ⇄ 255	0–100%
29	Plate pixel 7 green	000 ⇄ 255	0–100%
30	Plate pixel 7 blue	000 ⇄ 255	0–100%
31	Plate pixel 8 red	000 ⇄ 255	0–100%
32	Plate pixel 8 green	000 ⇄ 255	0–100%
33	Plate pixel 8 blue	000 ⇄ 255	0–100%
34	Plate pixel 9 red	000 ⇄ 255	0–100%
35	Plate pixel 9 green	000 ⇄ 255	0–100%
36	Plate pixel 9 blue	000 ⇄ 255	0–100%
37	Plate pixel 10 red	000 ⇄ 255	0–100%
38	Plate pixel 10 green	000 ⇄ 255	0–100%
39	Plate pixel 10 blue	000 ⇄ 255	0–100%
40	Plate pixel 11 red	000 ⇄ 255	0–100%
41	Plate pixel 11 green	000 ⇄ 255	0–100%
42	Plate pixel 11 blue	000 ⇄ 255	0–100%
43	Plate pixel 12 red	000 ⇄ 255	0–100%
44	Plate pixel 12 green	000 ⇄ 255	0–100%
45	Plate pixel 12 blue	000 ⇄ 255	0–100%
46	Plate pixel 13 red	000 ⇄ 255	0–100%
47	Plate pixel 13 green	000 ⇄ 255	0–100%
48	Plate pixel 13 blue	000 ⇄ 255	0–100%

Operation

Channel	Function	Value	Percent/Setting
49	Plate pixel 14 red	000 ⇄ 255	0–100%
50	Plate pixel 14 green	000 ⇄ 255	0–100%
51	Plate pixel 14 blue	000 ⇄ 255	0–100%
52	Beam pixel 1	000 ⇄ 255	0–100%
53	Beam pixel 2	000 ⇄ 255	0–100%
54	Beam pixel 3	000 ⇄ 255	0–100%
55	Beam pixel 4	000 ⇄ 255	0–100%
56	Beam pixel 5	000 ⇄ 255	0–100%
57	Beam pixel 6	000 ⇄ 255	0–100%
58	Beam pixel 7	000 ⇄ 255	0–100%
59	Beam pixel 8	000 ⇄ 255	0–100%
60	Beam pixel 9	000 ⇄ 255	0–100%
61	Beam pixel 10	000 ⇄ 255	0–100%
62	Beam pixel 11	000 ⇄ 255	0–100%
63	Beam pixel 12	000 ⇄ 255	0–100%
64	Beam pixel 13	000 ⇄ 255	0–100%
65	Beam pixel 14	000 ⇄ 255	0–100%
66	Beam pixel 15	000 ⇄ 255	0–100%
67	Beam pixel 16	000 ⇄ 255	0–100%
68	Beam pixel 17	000 ⇄ 255	0–100%
69	Beam pixel 18	000 ⇄ 255	0–100%
70	Beam pixel 19	000 ⇄ 255	0–100%
71	Beam pixel 20	000 ⇄ 255	0–100%
72	Beam pixel 21	000 ⇄ 255	0–100%
73	Beam pixel 22	000 ⇄ 255	0–100%
74	Beam pixel 23	000 ⇄ 255	0–100%
75	Beam pixel 24	000 ⇄ 255	0–100%
76	Beam pixel 25	000 ⇄ 255	0–100%
77	Beam pixel 26	000 ⇄ 255	0–100%
78	Beam pixel 27	000 ⇄ 255	0–100%
79	Beam pixel 28	000 ⇄ 255	0–100%
80	Beam FX	000 ⇄ 005	No function
		006 ⇄ 042	Ramp up
		043 ⇄ 085	Ramp down
		086 ⇄ 128	Ramp up-down
		129 ⇄ 171	Random
		172 ⇄ 214	Lightning
		215 ⇄ 255	Spikes

Channel	Function	Value	Percent/Setting
81	Plates foreground	000 ⇔ 000	No function
		001 ⇔ 002	White (2700K)
		003 ⇔ 004	White (3200K)
		005 ⇔ 006	White (4200K)
		007 ⇔ 008	White (5600K)
		009 ⇔ 010	White (8000K)
		011	Blue R: 0 G: 0 B: 255 W: 0
		012 ⇔ 048	Green+ / Blue R: 0 G: + B: 255 W: 0
		049	Cyan R: 0 G: 255 B: 255 W: 0
		050 ⇔ 086	Green / Blue- R: 0 G: 255 B: - W: 0
		087	Green R: 0 G: 255 B: 0 W: 0
		088 ⇔ 124	Red+ / Green R: + G: 255 B: 0 W: 0
		125	Yellow R: 255 G: 255 B: 0 W: 0
		126 ⇔ 162	Red / Green- R: 255 G: - B: 0 W: 0
		163	Red R: 255 G: 0 B: 0 W: 0
		164 ⇔ 200	Red / Blue+ R: 255 G: 0 B: + W: 0
		201	Magenta R: 255 G: 0 B: 255 W: 0
		202 ⇔ 238	Red- / Blue R: - G: 0 B: 255 W: 0
		239	Blue R: 0 G: 0 B: 255 W: 0
		240 ⇔ 247	Color index, fast to slow
248 ⇔ 255	Color snap, fast to slow		
82	Plate foreground dimmer	000 ⇔ 255	0-100%

Channel	Function	Value	Percent/Setting
83	Plates background	000 ⇔ 000	No function
		001 ⇔ 002	White (2700K)
		003 ⇔ 004	White (3200K)
		005 ⇔ 006	White (4200K)
		007 ⇔ 008	White (5600K)
		009 ⇔ 010	White (8000K)
		011	Blue R: 0 G: 0 B: 255 W: 0
		012 ⇔ 048	Green+ / Blue R: 0 G: + B: 255 W: 0
		049	Cyan R: 0 G: 255 B: 255 W: 0
		050 ⇔ 086	Green / Blue- R: 0 G: 255 B: - W: 0
		087	Green R: 0 G: 255 B: 0 W: 0
		088 ⇔ 124	Red+ / Green R: + G: 255 B: 0 W: 0
		125	Yellow R: 255 G: 255 B: 0 W: 0
		126 ⇔ 162	Red / Green- R: 255 G: - B: 0 W: 0
		163	Red R: 255 G: 0 B: 0 W: 0
		164 ⇔ 200	Red / Blue+ R: 255 G: 0 B: + W: 0
		201	Magenta R: 255 G: 0 B: 255 W: 0
202 ⇔ 238	Red- / Blue R: - G: 0 B: 255 W: 0		
239	Blue R: 0 G: 0 B: 255 W: 0		
240 ⇔ 247	Color index, fast to slow		
248 ⇔ 255	Color snap, fast to slow		
84	Plates background dimmer	000 ⇔ 255	0–100%
85	Plate 1 (pixels 1–7) FX select (see Pixel Mapping)	000 ⇔ 002 003 ⇔ 255	Plate FX All select (all on) Plate FX pattern select
86	Plate 1 (pixels 1–7) FX movement speed & direction (see Pixel Mapping)	000 ⇔ 005 006 ⇔ 124 125 ⇔ 130 131 ⇔ 249 250 ⇔ 255	No function Left to right, fast to slow No function Right to left, slow to fast No function
87	Plate 1 (pixels 1–7) FX crossfade (see Pixel Mapping)	000 ⇔ 002 003 ⇔ 255	Snap from pixel to pixel Fade duration: short to long
88	Plate 2 (pixels 8–14) FX select (see Pixel Mapping)	000 ⇔ 002 003 ⇔ 255	Plate FX All select (all on) Plate FX pattern select
89	Plate 2 (pixels 8–14) FX movement speed & direction (see Pixel Mapping)	000 ⇔ 005 006 ⇔ 124 125 ⇔ 130 131 ⇔ 249 250 ⇔ 255	No function Left to right, fast to slow No function Right to left, slow to fast No function
90	Plate 2 (pixels 8–14) FX crossfade (see Pixel Mapping)	000 ⇔ 002 003 ⇔ 255	Snap from pixel to pixel Fade duration: short to long
91	Beam 1 (pixels 1–14) FX select (see Pixel Mapping)	000 ⇔ 002 003 ⇔ 255	Beam FX All select (all on) Beam FX pattern select
92	Beam 1 (pixels 1–14) FX movement speed & direction (see Pixel Mapping)	000 ⇔ 005 006 ⇔ 124 125 ⇔ 130 131 ⇔ 249 250 ⇔ 255	No function Left to right, fast to slow No function Right to left, slow to fast No function
93	Beam 1 (pixels 1–14) FX crossfade (see Pixel Mapping)	000 ⇔ 002 003 ⇔ 255	Snap from pixel to pixel Fade duration: short to long

Channel	Function	Value	Percent/Setting
94	Beam 2 (pixels 15–28) FX select (see Pixel Mapping)	000 ⇄ 002	Beam FX All select (all on)
		003 ⇄ 255	Beam FX pattern select
95	Beam 2 (pixels 15–28) FX movement speed & direction (see Pixel Mapping)	000 ⇄ 005	No function
		006 ⇄ 124	Left to right, fast to slow
		125 ⇄ 130	No function
		131 ⇄ 249	Right to left, slow to fast
96	Beam 2 (pixels 15–28) FX crossfade (see Pixel Mapping)	000 ⇄ 002	Snap from pixel to pixel
		003 ⇄ 255	Fade duration: short to long
97	Control* (hold for 3 seconds)	000 ⇄ 005	No function
		006 ⇄ 010	Off (dimmer mode)
		011 ⇄ 015	Dimmer 1 (dimmer mode)
		016 ⇄ 020	Dimmer 2 (dimmer mode)
		021 ⇄ 025	Dimmer 3 (dimmer mode)
		026 ⇄ 030	600 Hz
		031 ⇄ 035	1200 Hz
		036 ⇄ 040	2000 Hz
		041 ⇄ 045	4000 Hz
		046 ⇄ 050	6000 Hz
		051 ⇄ 055	25 KHz
		056 ⇄ 060	Auto (Fan mode)
		061 ⇄ 065	On (Fan mode)
		066 ⇄ 070	Tilt reset
		071 ⇄ 075	Plate 1 invert off
		076 ⇄ 080	Plate 1 invert on
		081 ⇄ 085	Plate 2 invert off
		086 ⇄ 090	Plate 2 invert on
		091 ⇄ 095	Beam 1 invert off
		096 ⇄ 100	Beam 1 invert on
		101 ⇄ 105	Beam 2 invert off
		106 ⇄ 110	Beam 2 invert on
		111 ⇄ 115	Plate swap on
116 ⇄ 120	Plate swap off		
121 ⇄ 125	Beam swap on		
126 ⇄ 130	Beam swap off		
131 ⇄ 140	No function		
141 ⇄ 150	FX pattern priority		
151 ⇄ 155	Color mix HTP on		
156 ⇄ 160	Color mix HTP off		
161 ⇄ 170	Color priority		
171 ⇄ 255	No function		



***Hold desired dimmer speed value for 3 seconds, then release. This changes the dimmer speed setting in the menu.**

Operation

74CH

Channel	Function	Value	Percent/Setting
1	Tilt	000 ⇄ 255	0–100%
2	Fine tilt	000 ⇄ 255	0–100%
3	Dimmer	000 ⇄ 255	0–100%
4	Strobe	000 ⇄ 009	Open
		010 ⇄ 079	Strobe, slow to fast
		080 ⇄ 149	Pulse, slow to fast
		150 ⇄ 219	Random strobe, slow to fast
		220 ⇄ 255	Open
5	Plate pixel 1 red	000 ⇄ 255	0–100%
6	Plate pixel 1 green	000 ⇄ 255	0–100%
7	Plate pixel 1 blue	000 ⇄ 255	0–100%
8	Plate pixel 2 red	000 ⇄ 255	0–100%
9	Plate pixel 2 green	000 ⇄ 255	0–100%
10	Plate pixel 2 blue	000 ⇄ 255	0–100%
11	Plate pixel 3 red	000 ⇄ 255	0–100%
12	Plate pixel 3 green	000 ⇄ 255	0–100%
13	Plate pixel 3 blue	000 ⇄ 255	0–100%
14	Plate pixel 4 red	000 ⇄ 255	0–100%
15	Plate pixel 4 green	000 ⇄ 255	0–100%
16	Plate pixel 4 blue	000 ⇄ 255	0–100%
17	Plate pixel 5 red	000 ⇄ 255	0–100%
18	Plate pixel 5 green	000 ⇄ 255	0–100%
19	Plate pixel 5 blue	000 ⇄ 255	0–100%
20	Plate pixel 6 red	000 ⇄ 255	0–100%
21	Plate pixel 6 green	000 ⇄ 255	0–100%
22	Plate pixel 6 blue	000 ⇄ 255	0–100%
23	Plate pixel 7 red	000 ⇄ 255	0–100%
24	Plate pixel 7 green	000 ⇄ 255	0–100%
25	Plate pixel 7 blue	000 ⇄ 255	0–100%
26	Plate pixel 8 red	000 ⇄ 255	0–100%
27	Plate pixel 8 green	000 ⇄ 255	0–100%
28	Plate pixel 8 blue	000 ⇄ 255	0–100%
29	Plate pixel 9 red	000 ⇄ 255	0–100%
30	Plate pixel 9 green	000 ⇄ 255	0–100%
31	Plate pixel 9 blue	000 ⇄ 255	0–100%
32	Plate pixel 10 red	000 ⇄ 255	0–100%
33	Plate pixel 10 green	000 ⇄ 255	0–100%
34	Plate pixel 10 blue	000 ⇄ 255	0–100%
35	Plate pixel 11 red	000 ⇄ 255	0–100%
36	Plate pixel 11 green	000 ⇄ 255	0–100%
37	Plate pixel 11 blue	000 ⇄ 255	0–100%
38	Plate pixel 12 red	000 ⇄ 255	0–100%
39	Plate pixel 12 green	000 ⇄ 255	0–100%
40	Plate pixel 12 blue	000 ⇄ 255	0–100%
41	Plate pixel 13 red	000 ⇄ 255	0–100%
42	Plate pixel 13 green	000 ⇄ 255	0–100%
43	Plate pixel 13 blue	000 ⇄ 255	0–100%
44	Plate pixel 14 red	000 ⇄ 255	0–100%

Channel	Function	Value	Percent/Setting
45	Plate pixel 14 green	000 ⇄ 255	0–100%
46	Plate pixel 14 blue	000 ⇄ 255	0–100%
47	Beam pixel 1	000 ⇄ 255	0–100%
48	Beam pixel 2	000 ⇄ 255	0–100%
49	Beam pixel 3	000 ⇄ 255	0–100%
50	Beam pixel 4	000 ⇄ 255	0–100%
51	Beam pixel 5	000 ⇄ 255	0–100%
52	Beam pixel 6	000 ⇄ 255	0–100%
53	Beam pixel 7	000 ⇄ 255	0–100%
54	Beam pixel 8	000 ⇄ 255	0–100%
55	Beam pixel 9	000 ⇄ 255	0–100%
56	Beam pixel 10	000 ⇄ 255	0–100%
57	Beam pixel 11	000 ⇄ 255	0–100%
58	Beam pixel 12	000 ⇄ 255	0–100%
59	Beam pixel 13	000 ⇄ 255	0–100%
60	Beam pixel 14	000 ⇄ 255	0–100%
61	Beam pixel 15	000 ⇄ 255	0–100%
62	Beam pixel 16	000 ⇄ 255	0–100%
63	Beam pixel 17	000 ⇄ 255	0–100%
64	Beam pixel 18	000 ⇄ 255	0–100%
65	Beam pixel 19	000 ⇄ 255	0–100%
66	Beam pixel 20	000 ⇄ 255	0–100%
67	Beam pixel 21	000 ⇄ 255	0–100%
68	Beam pixel 22	000 ⇄ 255	0–100%
69	Beam pixel 23	000 ⇄ 255	0–100%
70	Beam pixel 24	000 ⇄ 255	0–100%
71	Beam pixel 25	000 ⇄ 255	0–100%
72	Beam pixel 26	000 ⇄ 255	0–100%
73	Beam pixel 27	000 ⇄ 255	0–100%
74	Beam pixel 28	000 ⇄ 255	0–100%

Operation

47CH

Channel	Function	Value	Percent/Setting
1	Tilt	000 ⇄ 255	0–100%
2	Fine tilt	000 ⇄ 255	0–100%
3	Master dimmer	000 ⇄ 255	0–100%
4	Plate dimmer	000 ⇄ 255	0–100%
5	Beam dimmer	000 ⇄ 255	0–100%
6	Plate flash duration	000 ⇄ 009	Classic shutter mode: disables duration control
		010 ⇄ 250	Slow to fast
		251 ⇄ 255	100% On, no flash/strobe
7	Plate flash rate	000 ⇄ 009	100% On, no flash/strobe
		010 ⇄ 250	Slow to fast
		251 ⇄ 255	100% On, no flash/strobe
8	Beam flash duration	000 ⇄ 009	Classic shutter mode: disables duration control
		010 ⇄ 250	Slow to fast
		251 ⇄ 255	100% On, no flash/strobe
9	Beam flash rate	000 ⇄ 009	100% On, no flash/strobe
		010 ⇄ 250	Slow to fast
		251 ⇄ 255	100% On, no flash/strobe
10	Plate Invert	000 ⇄ 005	Normal alignment
		006 ⇄ 124	Invert Plate 1 and Plate 2
		125 ⇄ 130	Invert Plate 1, Plate 2 normal
		131 ⇄ 249	Invert Plate 2, Plate 1 normal
		250 ⇄ 255	No function
11	Beam Invert	000 ⇄ 005	Normal alignment
		006 ⇄ 124	Invert Beam 1 and Beam 2
		125 ⇄ 130	Invert Beam 1, Beam 2 normal
		131 ⇄ 249	Invert Beam 2, Beam 1 normal
		250 ⇄ 255	No function
12	Plate Pixel 1 + 8 Red	000 ⇄ 255	0–100%
13	Plate Pixel 1 + 8 Green	000 ⇄ 255	0–100%
14	Plate Pixel 1 + 8 Blue	000 ⇄ 255	0–100%
15	Plate Pixel 2 + 9 Red	000 ⇄ 255	0–100%
16	Plate Pixel 2 + 9 Green	000 ⇄ 255	0–100%
17	Plate Pixel 2 + 9 Blue	000 ⇄ 255	0–100%
18	Plate Pixel 3 + 10 Red	000 ⇄ 255	0–100%
19	Plate Pixel 3 + 10 Green	000 ⇄ 255	0–100%
20	Plate Pixel 3 + 10 Blue	000 ⇄ 255	0–100%
21	Plate Pixel 4 + 11 Red	000 ⇄ 255	0–100%
22	Plate Pixel 4 + 11 Green	000 ⇄ 255	0–100%
23	Plate Pixel 4 + 11 Blue	000 ⇄ 255	0–100%
24	Plate Pixel 5 + 12 Red	000 ⇄ 255	0–100%
25	Plate Pixel 5 + 12 Green	000 ⇄ 255	0–100%
26	Plate Pixel 5 + 12 Blue	000 ⇄ 255	0–100%
27	Plate Pixel 6 + 13 Red	000 ⇄ 255	0–100%
28	Plate Pixel 6 + 13 Green	000 ⇄ 255	0–100%
29	Plate Pixel 6 + 13 Blue	000 ⇄ 255	0–100%
30	Plate Pixel 7 + 14 Red	000 ⇄ 255	0–100%
31	Plate Pixel 7 + 14 Green	000 ⇄ 255	0–100%
32	Plate Pixel 7 + 14 Blue	000 ⇄ 255	0–100%

Channel	Function	Value	Percent/Setting
33	Beam Pixel 1 + 15	000 ⇄ 255	0–100%
34	Beam Pixel 2 + 16	000 ⇄ 255	0–100%
35	Beam Pixel 3 + 17	000 ⇄ 255	0–100%
36	Beam Pixel 4 + 18	000 ⇄ 255	0–100%
37	Beam Pixel 5 + 19	000 ⇄ 255	0–100%
38	Beam Pixel 6 + 20	000 ⇄ 255	0–100%
39	Beam Pixel 7 + 21	000 ⇄ 255	0–100%
40	Beam Pixel 8 + 22	000 ⇄ 255	0–100%
41	Beam Pixel 9 + 23	000 ⇄ 255	0–100%
42	Beam Pixel 10 + 24	000 ⇄ 255	0–100%
43	Beam Pixel 11 + 25	000 ⇄ 255	0–100%
44	Beam Pixel 12 + 26	000 ⇄ 255	0–100%
45	Beam Pixel 13 + 27	000 ⇄ 255	0–100%
46	Beam Pixel 14 + 28	000 ⇄ 255	0–100%
47	Control*	000 ⇄ 005	No function
		006 ⇄ 010	Off (dimmer mode)
		011 ⇄ 015	Dimmer 1 (dimmer mode)
		016 ⇄ 020	Dimmer 2 (dimmer mode)
		021 ⇄ 025	Dimmer 3 (dimmer mode)
		026 ⇄ 030	600 Hz
		031 ⇄ 035	1200 Hz
		036 ⇄ 040	2000 Hz
		041 ⇄ 045	4000 Hz
		046 ⇄ 050	6000 Hz
		051 ⇄ 055	25KHz
		056 ⇄ 060	Auto (fan mode)
		061 ⇄ 065	On (fan mode)
		066 ⇄ 070	Tilt reset
		071 ⇄ 075	Plate 1 – invert off
		076 ⇄ 080	Plate 1– invert on
		081 ⇄ 085	Plate 2 – invert off
		086 ⇄ 090	Plate 2 – invert on
		091 ⇄ 095	Beam 1 – invert off
		096 ⇄ 100	Beam 1 – invert on
		101 ⇄ 105	Beam 2 – invert off
		106 ⇄ 110	Beam 2 – invert on
		111 ⇄ 115	Plate swap on
		116 ⇄ 120	Plate swap off
121 ⇄ 125	Beam swap on		
126 ⇄ 130	Beam swap off		
131 ⇄ 140	No function		
141 ⇄ 150	No function		
151 ⇄ 155	No function		
156 ⇄ 160	No function		
161 ⇄ 170	No function		
171 ⇄ 255	No function		



*Hold desired dimmer speed value for 3 seconds, then release. This changes the dimmer speed setting in the menu.

Operation

30CH

Channel	Function	Value	Percent/Setting
1	Tilt	000 ⇄ 255	0–100%
2	Fine tilt	000 ⇄ 255	0–100%
3	Master dimmer	000 ⇄ 255	0–100%
4	Plate dimmer	000 ⇄ 255	0–100%
5	Beam dimmer	000 ⇄ 255	0–100%
6	Plate flash duration	000 ⇄ 009	Classic shutter mode: disables duration control
		010 ⇄ 250	Slow to fast
		251 ⇄ 255	100% On, no flash/strobe
7	Plate flash rate	000 ⇄ 009	100%
		010 ⇄ 250	Slow to fast
		251 ⇄ 255	100%
8	Beam flash duration	000 ⇄ 009	Classic shutter mode: disables duration control
		010 ⇄ 250	Slow to fast
		251 ⇄ 255	100% On, no flash/strobe
9	Beam flash rate	000 ⇄ 009	100%
		010 ⇄ 250	Slow to fast
		251 ⇄ 255	100% on
10	Plates red	000 ⇄ 255	0–100%
11	Plates green	000 ⇄ 255	0–100%
12	Plates blue	000 ⇄ 255	0–100%
13	Beam FX	000 ⇄ 005	No function
		006 ⇄ 042	Ramp up
		043 ⇄ 085	Ramp down
		086 ⇄ 128	Ramp up-down
		129 ⇄ 171	Random
		172 ⇄ 214	Lightning
		215 ⇄ 255	Spikes

Channel	Function	Value	Percent/Setting
14	Plates foreground	000 ⇔ 000	No function
		001 ⇔ 002	White (2700K)
		003 ⇔ 004	White (3200K)
		005 ⇔ 006	White (4200K)
		007 ⇔ 008	White (5600K)
		009 ⇔ 010	White (8000K)
		011	Blue R: 0 G: 0 B: 255 W: 0
		012 ⇔ 048	Green+ / Blue R: 0 G: + B: 255 W: 0
		049	Cyan R: 0 G: 255 B: 255 W: 0
		050 ⇔ 086	Green / Blue- R: 0 G: 255 B: - W: 0
		087	Green R: 0 G: 255 B: 0 W: 0
		088 ⇔ 124	Red+ / Green R: + G: 255 B: 0 W: 0
		125	Yellow R: 255 G: 255 B: 0 W: 0
		126 ⇔ 162	Red / Green- R: 255 G: - B: 0 W: 0
		163	Red R: 255 G: 0 B: 0 W: 0
		164 ⇔ 200	Red / Blue+ R: 255 G: 0 B: + W: 0
		201	Magenta R: 255 G: 0 B: 255 W: 0
		202 ⇔ 238	Red- / Blue R: - G: 0 B: 255 W: 0
		239	Blue R: 0 G: 0 B: 255 W: 0
		240 ⇔ 247	Color index, fast to slow
248 ⇔ 255	Color snap, fast to slow		
15	Plates foreground dimmer	000 ⇔ 255	0–100%

Channel	Function	Value	Percent/Setting
16	Plates background	000 ⇔ 000	No function
		001 ⇔ 002	White (2700K)
		003 ⇔ 004	White (3200K)
		005 ⇔ 006	White (4200K)
		007 ⇔ 008	White (5600K)
		009 ⇔ 010	White (8000K)
		011	Blue R: 0 G: 0 B: 255 W: 0
		012 ⇔ 048	Green+ / Blue R: 0 G: + B: 255 W: 0
		049	Cyan R: 0 G: 255 B: 255 W: 0
		050 ⇔ 086	Green / Blue- R: 0 G: 255 B: - W: 0
		087	Green R: 0 G: 255 B: 0 W: 0
		088 ⇔ 124	Red+ / Green R: + G: 255 B: 0 W: 0
		125	Yellow R: 255 G: 255 B: 0 W: 0
		126 ⇔ 162	Red / Green- R: 255 G: - B: 0 W: 0
		163	Red R: 255 G: 0 B: 0 W: 0
		164 ⇔ 200	Red / Blue+ R: 255 G: 0 B: + W: 0
		201	Magenta R: 255 G: 0 B: 255 W: 0
202 ⇔ 238	Red- / Blue R: - G: 0 B: 255 W: 0		
239	Blue R: 0 G: 0 B: 255 W: 0		
240 ⇔ 247	Color index, fast to slow		
248 ⇔ 255	Color snap, fast to slow		
17	Plates background dimmer	000 ⇔ 255	0–100%
18	Plate 1 (pixels 1–7) FX select	000 ⇔ 002 003 ⇔ 255	Plate FX All select (all on) see Plate Patterns
19	Plate 1 (pixels 1–7) FX movement speed & direction	000 ⇔ 005 006 ⇔ 124 125 ⇔ 130 131 ⇔ 249 250 ⇔ 255	No function Left to right, fast to slow No function Right to left, slow to fast No function
20	Plate 1 (pixels 1–7) FX crossfade	000 ⇔ 002 003 ⇔ 255	Snap from cell to cell Fade duration: short to long
21	Plate 2 (pixels 8–14) FX select	000 ⇔ 002 003 ⇔ 255	Plate FX All select (all on) see Plate Patterns
22	Plate 2 (pixels 8–14) FX movement speed & direction	000 ⇔ 005 006 ⇔ 124 125 ⇔ 130 131 ⇔ 249 250 ⇔ 255	No function Left to right, fast to slow No function Right to left, slow to fast No function
23	Plate 2 (pixels 8–14) FX crossfade	000 ⇔ 002 003 ⇔ 255	Snap from cell to cell Fade duration: short to long
24	Beam 1 (pixels 1–14) FX select	000 ⇔ 002 003 ⇔ 255	Beam FX All select (all on) see Beam Patterns

Channel	Function	Value	Percent/Setting
25	Beam 1 (pixels 1–14) FX movement speed & direction	000 ⇔ 005	No function
		006 ⇔ 124	Left to right, fast to slow
		125 ⇔ 130	No function
		131 ⇔ 249	Right to left, slow to fast
		250 ⇔ 255	No function
26	Beam 1 (pixels 1–14) FX crossfade	000 ⇔ 002	Snap from cell to cell
		003 ⇔ 255	Fade duration: short to long
27	Beam 2 (pixels 15–28) FX select	000 ⇔ 002	Beam FX All select (all on)
		003 ⇔ 255	see Beam Patterns
28	Beam 2 (pixels 15–28) FX movement speed & direction	000 ⇔ 005	No function
		006 ⇔ 124	Left to right, fast to slow
		125 ⇔ 130	No function
		131 ⇔ 249	Right to left, slow to fast
		250 ⇔ 255	No function
29	Beam 2 (pixels 15–28) FX crossfade	000 ⇔ 002	Snap from cell to cell
		003 ⇔ 255	Fade duration: short to long
30	Control*	000 ⇔ 005	No function
		006 ⇔ 010	Off (dimmer mode)
		011 ⇔ 015	Dimmer 1
		016 ⇔ 020	Dimmer 2
		021 ⇔ 025	Dimmer 3
		026 ⇔ 030	600 Hz
		031 ⇔ 035	1200 Hz
		036 ⇔ 040	2000 Hz
		041 ⇔ 045	4000 Hz
		046 ⇔ 050	6000 Hz
		051 ⇔ 055	25 KHz
		056 ⇔ 060	Fan mode auto
		061 ⇔ 065	Fan mode on
		066 ⇔ 070	Tilt reset
		071 ⇔ 075	Plate1 invert off
		076 ⇔ 080	Plate1 invert on
		081 ⇔ 085	Plate2 invert off
		086 ⇔ 090	Plate2 invert on
		091 ⇔ 095	Beam1 invert off
		096 ⇔ 100	Beam1 invert on
		101 ⇔ 105	Beam2 invert off
		106 ⇔ 110	Beam2 invert on
		111 ⇔ 115	Plate swap on
		116 ⇔ 120	Plate swap off
		121 ⇔ 125	Beam swap on
126 ⇔ 130	Beam swap off		
131 ⇔ 140	No function		
141 ⇔ 150	No function		
151 ⇔ 155	No function		
156 ⇔ 160	No function		
161 ⇔ 170	No function		
171 ⇔ 255	No function		

Operation



*Hold desired dimmer speed value for 3 seconds, then release. This changes the dimmer speed setting in the menu.

24CH

Channel	Function	Value	Percent/Setting
1	Tilt	000 ⇄ 255	0–100%
2	Fine tilt	000 ⇄ 255	0–100%
3	Master dimmer	000 ⇄ 255	0–100%
4	Plate dimmer	000 ⇄ 255	0–100%
5	Beam dimmer	000 ⇄ 255	0–100%
6	Plate flash duration	000 ⇄ 009	Classic shutter mode: disables duration control
		010 ⇄ 250	Slow to fast
		251 ⇄ 255	100% On, no flash/strobe
7	Plate flash rate	000 ⇄ 009	100%
		010 ⇄ 250	Slow to fast
		251 ⇄ 255	100%
8	Beam flash duration	000 ⇄ 009	Classic shutter mode: disables duration control
		010 ⇄ 250	Slow to fast
		251 ⇄ 255	100% On, no flash/strobe
9	Beam flash rate	000 ⇄ 009	100%
		010 ⇄ 250	Slow to fast
		251 ⇄ 255	100% on
10	Plates red	000 ⇄ 255	0–100%
11	Plates green	000 ⇄ 255	0–100%
12	Plates blue	000 ⇄ 255	0–100%
13	Beam FX	000 ⇄ 005	No function
		006 ⇄ 042	Ramp up
		043 ⇄ 085	Ramp down
		086 ⇄ 128	Ramp up-down
		129 ⇄ 171	Random
		172 ⇄ 214	Lightning
215 ⇄ 255	Spikes		

Channel	Function	Value	Percent/Setting				
14	Plates foreground	000 ⇔ 000	No function				
		001 ⇔ 002	White (2700K)				
		003 ⇔ 004	White (3200K)				
		005 ⇔ 006	White (4200K)				
		007 ⇔ 008	White (5600K)				
		009 ⇔ 010	White (8000K)				
		011	Blue	R: 0	G: 0	B: 255	W: 0
		012 ⇔ 048	Green+ / Blue	R: 0	G: +	B: 255	W: 0
		049	Cyan	R: 0	G: 255	B: 255	W: 0
		050 ⇔ 086	Green / Blue-	R: 0	G: 255	B: -	W: 0
		087	Green	R: 0	G: 255	B: 0	W: 0
		088 ⇔ 124	Red+ / Green	R: +	G: 255	B: 0	W: 0
		125	Yellow	R: 255	G: 255	B: 0	W: 0
		126 ⇔ 162	Red / Green-	R: 255	G: -	B: 0	W: 0
		163	Red	R: 255	G: 0	B: 0	W: 0
		164 ⇔ 200	Red / Blue+	R: 255	G: 0	B: +	W: 0
		201	Magenta	R: 255	G: 0	B: 255	W: 0
		202 ⇔ 238	Red- / Blue	R: -	G: 0	B: 255	W: 0
239	Blue	R: 0	G: 0	B: 255	W: 0		
240 ⇔ 247	Color index, fast to slow						
248 ⇔ 255	Color snap, fast to slow						
15	Plates foreground dimmer	000 ⇔ 255	0–100%				

Channel	Function	Value	Percent/Setting
16	Plates background	000 ⇔ 000	No function
		001 ⇔ 002	White (2700K)
		003 ⇔ 004	White (3200K)
		005 ⇔ 006	White (4200K)
		007 ⇔ 008	White (5600K)
		009 ⇔ 010	White (8000K)
		011	Blue R: 0 G: 0 B: 255 W: 0
		012 ⇔ 048	Green+ / Blue R: 0 G: + B: 255 W: 0
		049	Cyan R: 0 G: 255 B: 255 W: 0
		050 ⇔ 086	Green / Blue- R: 0 G: 255 B: - W: 0
		087	Green R: 0 G: 255 B: 0 W: 0
		088 ⇔ 124	Red+ / Green R: + G: 255 B: 0 W: 0
		125	Yellow R: 255 G: 255 B: 0 W: 0
		126 ⇔ 162	Red / Green- R: 255 G: - B: 0 W: 0
		163	Red R: 255 G: 0 B: 0 W: 0
		164 ⇔ 200	Red / Blue+ R: 255 G: 0 B: + W: 0
		201	Magenta R: 255 G: 0 B: 255 W: 0
		202 ⇔ 238	Red- / Blue R: - G: 0 B: 255 W: 0
239	Blue R: 0 G: 0 B: 255 W: 0		
240 ⇔ 247	Color index, fast to slow		
248 ⇔ 255	Color snap, fast to slow		
17	Plates background dimmer	000 ⇔ 255	0–100%
18	Plates 1 & 2 FX select	000 ⇔ 002 003 ⇔ 255	Plate FX All select (all on) see Plate Patterns
19	Plates 1 & 2 FX movement speed & direction	000 ⇔ 005 006 ⇔ 124 125 ⇔ 130 131 ⇔ 249 250 ⇔ 255	No function Left to right, fast to slow No function Right to left, slow to fast No function
20	Plates 1 & 2 FX crossfade	000 ⇔ 002 003 ⇔ 255	Snap from cell to cell Fade duration: short to long
21	Beams 1 & 2 FX select	000 ⇔ 002 003 ⇔ 255	Beam FX All select (all on) see Beam Patterns
22	Beams 1 & 2 FX movement speed & direction	000 ⇔ 005 006 ⇔ 124 125 ⇔ 130 131 ⇔ 249 250 ⇔ 255	No function Left to right, fast to slow No function Right to left, slow to fast No function
23	Beams 1 & 2 FX crossfade	000 ⇔ 002 003 ⇔ 255	Snap from cell to cell Fade duration: short to long

Channel	Function	Value	Percent/Setting
24	Control*	000 ⇔ 005	No function
		006 ⇔ 010	Off (dimmer mode)
		011 ⇔ 015	Dimmer 1
		016 ⇔ 020	Dimmer 2
		021 ⇔ 025	Dimmer 3
		026 ⇔ 030	600 Hz
		031 ⇔ 035	1200 Hz
		036 ⇔ 040	2000 Hz
		041 ⇔ 045	4000 Hz
		046 ⇔ 050	6000 Hz
		051 ⇔ 055	25 KHz
		056 ⇔ 060	Fan mode auto
		061 ⇔ 065	Fan mode on
		066 ⇔ 070	Tilt reset
		071 ⇔ 075	Plate1 invert off
		076 ⇔ 080	Plate1 invert on
		081 ⇔ 085	Plate2 invert off
		086 ⇔ 090	Plate2 invert on
		091 ⇔ 095	Beam1 invert off
		096 ⇔ 100	Beam1 invert on
		101 ⇔ 105	Beam2 invert off
		106 ⇔ 110	Beam2 invert on
		111 ⇔ 115	Plate swap on
		116 ⇔ 120	Plate swap off
		121 ⇔ 125	Beam swap on
126 ⇔ 130	Beam swap off		
131 ⇔ 140	No function		
141 ⇔ 150	No function		
151 ⇔ 155	No function		
156 ⇔ 160	No function		
161 ⇔ 170	No function		
171 ⇔ 255	No function		



*Hold desired dimmer speed value for 3 seconds, then release. This changes the dimmer speed setting in the menu.

13CH

Channel	Function	Value	Percent/Setting
1	Tilt	000 ⇔ 255	0–100%
2	Fine tilt	000 ⇔ 255	0–100%
3	Plate dimmer	000 ⇔ 255	0–100%
4	Beam dimmer	000 ⇔ 255	0–100%
5	Plate flash duration	000 ⇔ 009	Classic shutter mode: disables duration control
		010 ⇔ 250	Slow to fast
		251 ⇔ 255	100% On, no flash/strobe
6	Plate flash rate	000 ⇔ 009	100%
		010 ⇔ 250	Slow to fast
		251 ⇔ 255	100%
7	Beam flash duration	000 ⇔ 009	Classic shutter mode: disables duration control
		010 ⇔ 250	Slow to fast
		251 ⇔ 255	100% On, no flash/strobe

Operation

Channel	Function	Value	Percent/Setting
8	Beam flash rate	000 ⇄ 009	100%
		010 ⇄ 250	Slow to fast
		251 ⇄ 255	100% on
9	Plates red	000 ⇄ 255	0–100%
10	Plates green	000 ⇄ 255	0–100%
11	Plates blue	000 ⇄ 255	0–100%
12	Beam FX	000 ⇄ 005	No function
		006 ⇄ 042	Ramp up
		043 ⇄ 085	Ramp down
		086 ⇄ 128	Ramp up-down
		129 ⇄ 171	Random
		172 ⇄ 214	Lightning
		215 ⇄ 255	Spikes
13	Control*	000 ⇄ 005	No function
		006 ⇄ 010	Off (dimmer mode)
		011 ⇄ 015	Dimmer 1 (dimmer mode)
		016 ⇄ 020	Dimmer 2 (dimmer mode)
		021 ⇄ 025	Dimmer 3 (dimmer mode)
		026 ⇄ 030	600 Hz
		031 ⇄ 035	1200 Hz
		036 ⇄ 040	2000 Hz
		041 ⇄ 045	4000 Hz
		046 ⇄ 050	6000 Hz
		051 ⇄ 055	25 KHz
		056 ⇄ 060	Fan mode auto
		061 ⇄ 065	Fan mode on
		066 ⇄ 070	Tilt reset
		071 ⇄ 075	Plate1 invert off
		076 ⇄ 080	Plate1 invert on
		081 ⇄ 085	Plate2 invert off
		086 ⇄ 090	Plate2 invert on
		091 ⇄ 095	Beam1 invert off
		096 ⇄ 100	Beam1 invert on
		101 ⇄ 105	Beam2 invert off
		106 ⇄ 110	Beam2 invert on
		111 ⇄ 115	Plate swap on
		116 ⇄ 120	Plate swap off
		121 ⇄ 125	Beam swap on
		126 ⇄ 130	Beam swap off
		131 ⇄ 140	No function
141 ⇄ 150	No function		
151 ⇄ 155	No function		
156 ⇄ 160	No function		
161 ⇄ 170	No function		
171 ⇄ 255	No function		



*Hold desired dimmer speed value for 3 seconds, then release. This changes the dimmer speed setting in the menu.

11CH

Channel	Function	Value	Percent/Setting
1	Tilt	000 ⇔ 255	0–100%
2	Fine tilt	000 ⇔ 255	0–100%
3	Dimmer	000 ⇔ 255	0–100%
4	Plate flash duration	000 ⇔ 009	Classic shutter mode: disables duration control
		010 ⇔ 250	Slow to fast
		251 ⇔ 255	100% On, no flash/strobe
5	Plate flash rate	000 ⇔ 009	100%
		010 ⇔ 250	Slow to fast
		251 ⇔ 255	100%
6	Beam flash duration	000 ⇔ 009	Classic shutter mode: disables duration control
		010 ⇔ 250	Slow to fast
		251 ⇔ 255	100% On, no flash/strobe
7	Beam flash rate	000 ⇔ 009	100%
		010 ⇔ 250	Slow to fast
		251 ⇔ 255	100% on
8	Plates red	000 ⇔ 255	0–100%
9	Plates green	000 ⇔ 255	0–100%
10	Plates blue	000 ⇔ 255	0–100%
11	Beam	000 ⇔ 255	0–100%

8CH

Channel	Function	Value	Percent/Setting
1	Tilt	000 ⇔ 255	0–100%
2	Fine tilt	000 ⇔ 255	0–100%
3	Dimmer	000 ⇔ 255	0–100%
4	Strobe	000 ⇔ 009	Open
		010 ⇔ 079	Strobe, slow to fast
		080 ⇔ 149	Pulse, slow to fast
		150 ⇔ 219	Random strobe, slow to fast
		220 ⇔ 255	Open
5	Red	000 ⇔ 255	0–100%
6	Green	000 ⇔ 255	0–100%
7	Blue	000 ⇔ 255	0–100%
8	Beam	000 ⇔ 255	0–100%

Operation

Pixel Mapping

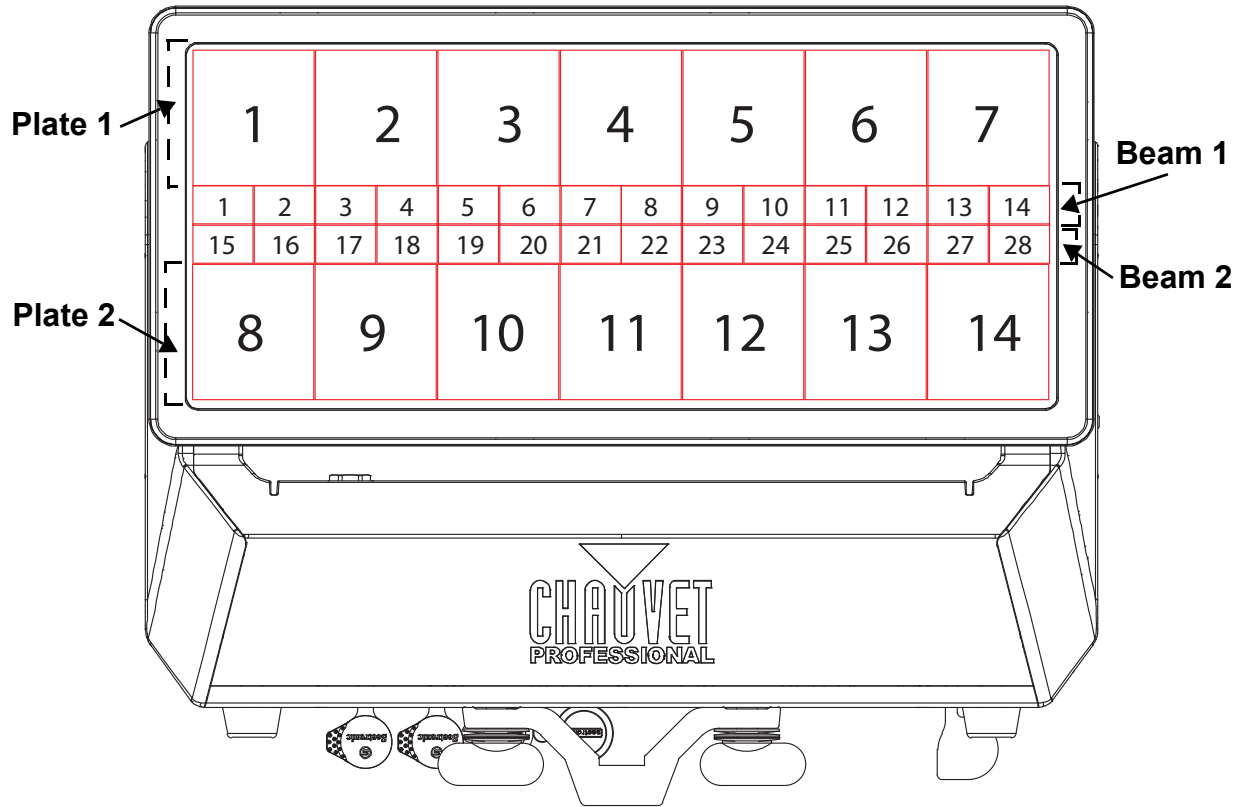
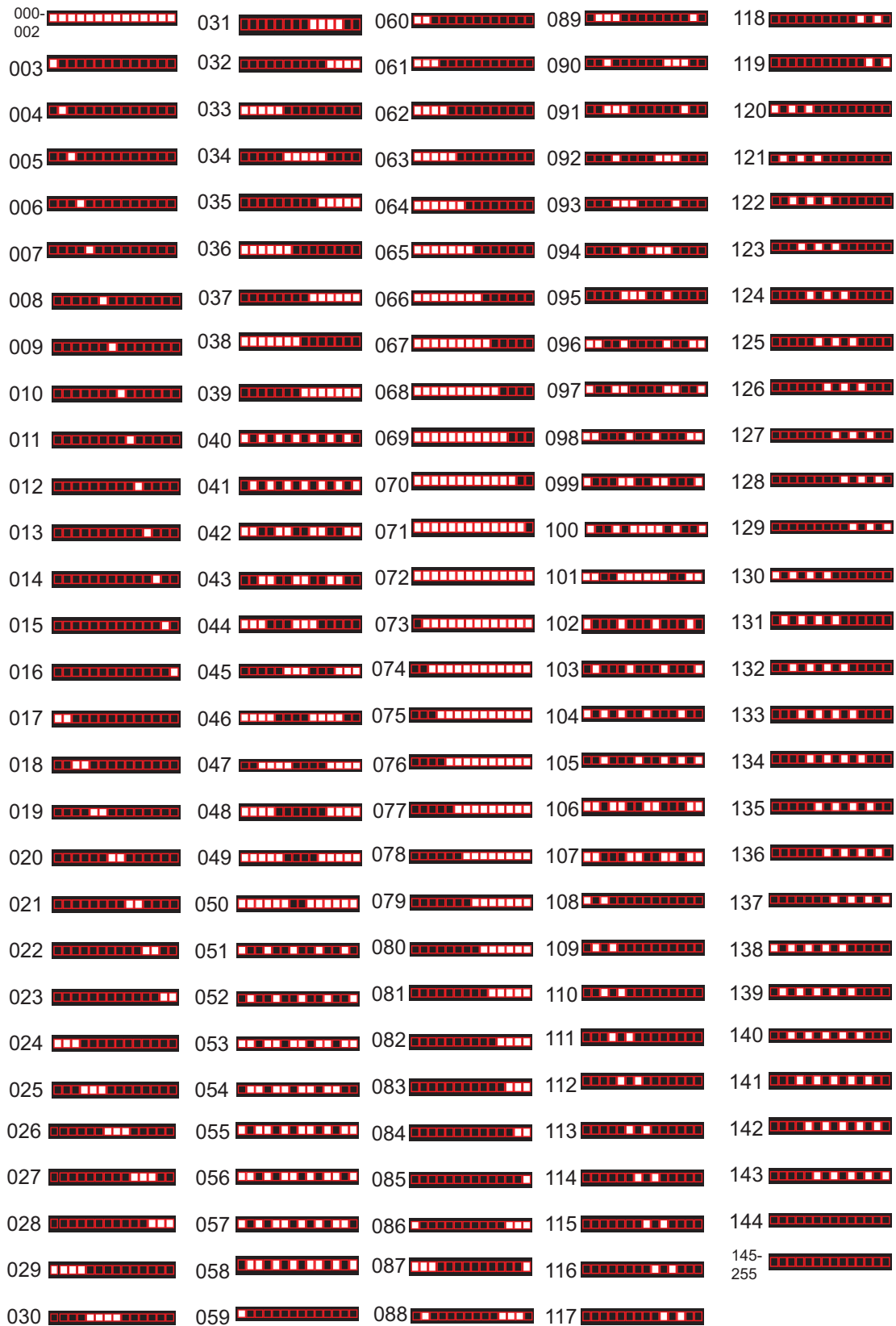

Plate Patterns

000- 002		022		042		062	
003		023		043		063	
004		024		044		064	
005		025		045		065	
006		026		046		066	
007		027		047		067	
008		028		048		068	
009		029		049		069	
010		030		050		070	
011		031		051		071	
012		032		052		072	
013		033		053		073	
014		034		054		074	
015		035		055		075	
016		036		056		076	
017		037		057		077	
018		038		058		078	
019		039		059		079	
020		040		060		080- 255	
021		041		061			

Beam Patterns



Configuration

Static Color

There are two options to run the Color STRIKE M on a static color setting: Fixed Color and Manual Color Mixer. The Static Fixed Color mode allows for permanent RGB presets without a DMX controller. To run the Static Fixed Color mode, do the following:

1. Go to the **Static** main level.
2. Select **Fixed Color**.
3. Choose among the preset RGB color options and combinations (**R, G, B, GB, RB, RG, and RGB**).

The Static Manual Color Mixer mode allows for permanent RGB color mixing without a DMX controller. To run the Static Manual Color Mixer mode, do the following:

1. Go to the **Static** main level.
2. Select **Manual Color Mixer**.
3. Choose among **Red, Green, or Blue**.
4. Adjust the color value from **0** to **255**.

Plate FX

This setting allows users to adjust the speed, intensity, and the background and foreground colors of each of the plate of the Color STRIKE M. To access these settings and choose a specific plate effect, follow the instructions below:

1. Go to the **Plate FX** main level.
2. Choose among **Plate FX 1–9**.

To adjust the speed of the effect:

1. Follow steps 1–2 above to choose a specific Plate FX.
2. Select **Speed**.
3. Adjust the speed from **1** (slowest) to **100** (fastest).

To adjust the intensity of the effect:

1. Follow steps 1–2 above to choose a specific Plate FX.
2. Select **Plate Intensity**.
3. Adjust the intensity from **0** (darkest) to **100** (brightest).

To choose the background or foreground color:

1. Follow steps 1–2 above to choose a specific Plate FX.
2. Select **Background Color** or **Foreground Color**.
3. Choose among the preset RGB color options and combinations (**R, G, B, GB, RB, RG, and RGB**) or **Off** (turns off the background or foreground color).

Beam Intensity

To adjust the beam intensity of the Color STRIKE M, do the following:

1. Go to the **Beam Intensity** main level.
2. Choose the intensity from **000** (darkest) to **255** (brightest).

Beam Flash Duration

To adjust the duration of the beam flash of the Color STRIKE M, do the following:

1. Go to the **Beam Flash Duration** main level.
2. Choose the intensity from **000** (slowest) to **255** (fastest).

Beam Flash Rate

To adjust the beam flash rate of the Color STRIKE M, do the following:

1. Go to the **Beam Flash Rate** main level.
2. Choose the intensity from **000–009** (always on), **010** (slowest), **250** (fastest) to **251–255** (always on).

Tilt

To adjust the tilt angle of the Color STRIKE M, follow the instructions below:

1. Go to the **Tilt** main level.
2. Choose from **000** (0°) to **255** (180°).

Tilt Offset

To set the tilt offset of the Color STRIKE M, do the following:

1. Go to the **Tilt Offset** main level.
2. Choose from **000** (0°) to **255** (180°).

Operation

Tilt Invert

To invert the default tilt orientation of the Color STRIKE M, do the following:

1. Go to the **Tilt Invert** main level.
2. Choose from **No** (keep default tilt orientation) to **Yes** (invert tilt orientation).

Pixel Invert

To invert the beam and plate pixels individually, do the following:

1. Go to the **Pixel invert** main level.
2. Choose which Plate (**Plate 1 Invert** or **Plate 2 Invert**) or Beam (**Tube 1 Invert** or **Tube 2 Invert**) to activate pixel invert.
3. Choose from **No** (keep default pixel orientation) or **Yes** (activate pixel invert).



The pixel orientation reverts to default setting with a factory reset.

LED Array Swap

To swap the beam and plate pixel mapping, do the following:

1. Go to the **LED Array Swap** main level.
2. Choose between **Plate Swap** and **Beam Swap**.
3. Choose from **No** (keep default pixel mapping) to **Yes** (invert pixel mapping).



The pixel mapping setting remains even after a factory reset.
To reset the LED Array Swap, use the Display, Control Channel, or RDM manufacture PIDS.

Master Slave

The Master/Slave mode allows a group of Color STRIKE M (the slaves) to simultaneously duplicate the output of another Color STRIKE M (the master) without a DMX controller. To set the Color STRIKE M product to master or slave mode, do the following:

1. Go to the **Master/Slave** main level.
2. Select from **Master** (sends control signal) or **Slave** (receives control signal).



- The master should be the first product in the daisy chain.
- Configure all the slave products before connecting the master to the daisy chain.
- Never connect a DMX controller to a DMX string configured for Master/Slave operation because the controller may interfere with the signals from the master.

Dimmer Mode

To select the dimmer mode, follow the instructions below:

1. Go to the **Dimmer Mode** main level.
2. Select from **Off** (linear dimmer) or **Dimmer 1–3** (fast to slow).

White Balance

To adjust the white balance, do the following:

1. Go to the **White Balance** main level.
2. Choose between **Off** (to turn off white balance) and **Manual** (to manually adjust the white balance).

To manually adjust the white balance using RGB color setting:

1. Go to the **White Balance** main level.
2. Choose **Manual**.
3. Select among **Red**, **Green**, and **Blue** color setting.
4. Choose the respective value for each color, from **000** to **255**.

Pulse Width Modulation

To set the PWM frequency, follow the instruction below:

1. Go to the **LED Frequency** main level.
2. Select from **600Hz**, **1200Hz**, **2000Hz**, **4000Hz**, or **25KHz**.

Display Invert

To invert the display on the Color STRIKE M, do the following:

1. Go to the **Display Invert** main level.
2. Select between **No** (keep default display setting) and **Yes** (invert display).

Display Back Light

To select how long a period of inactivity before the display automatically turns off:

1. Go to the **Back Light** main level.
2. Select from **10S** (10 seconds), **30S** (30 seconds), **2Min** (2 minutes), or **Always On**.

Key Lock

To lock or unlock the control panel:

1. Go to the **Key Lock** option.
2. Select **On** (locks control panel) or **Off** (control panel stays unlocked).



When the key lock is activated, the product will prompt for the passcode in order to access the menu. The passcode is <UP>, <DOWN>, <UP>, <DOWN>, <ENTER>.

Product Information

To view the product information:

1. Go to the **Information** main level.
2. Choose among:
 - **Fixture Hours** – to display the number of hours the fixture has been on
 - **LED Hours** – to display the total LED hours used
 - **Display Ver** – to display the current software version of the fixture
 - **Drv-Y Ver** – to display the tilt PCB version
 - **LED-A Ver** – to display the LED A PCB version
 - **LED-C Ver** – to display the LED C PCB version
 - **Net Ver** – to display the network version
 - **UID** – to display the fixture's unique identification (UID)

Factory Reset

To reset the product to factory default settings:

1. Go to the **Factory Reset** main level.
2. Select from **No** (cancel) or **Yes** (reset).

5. Maintenance

Product Maintenance

Dust build-up reduces light output performance and can cause overheating. This can lead to reduction of the light source's life and/or mechanical wear. To maintain optimum performance and minimize wear, clean all lighting products at least twice a month. However, be aware that usage and environmental conditions could be contributing factors to increase the cleaning frequency.

To clean the product, follow the instructions below:

1. Unplug the product from power.
2. Wait until the product is at room temperature.
3. Use a vacuum (or dry compressed air) and a soft brush to remove dust collected on the external surface/vents.
4. Clean all transparent surfaces with a mild soap solution, ammonia-free glass cleaner, or isopropyl alcohol.
5. Apply the solution directly to a soft, lint free cotton cloth or a lens cleaning tissue.
6. Softly drag any dirt or grime to the outside of the transparent surface.
7. Gently polish the transparent surfaces until they are free of haze and lint.



Always dry the transparent surfaces carefully after cleaning them.

6. Technical Specifications

Dimensions and Weight

Length	Width	Height	Weight
16.02 in (407 mm)	6.90 in (175.4 mm)	12.30 in (312.5 mm)	26.6 lb (12.1 kg)

Note: Dimensions in inches are rounded.

Power

Power Supply Type	Range	Voltage Selection
Switching (internal)	100 to 240 VAC, 50/60 Hz	Auto-ranging

Parameter	100 V, 60 Hz	120 V, 60 Hz	208 V, 60 Hz	230 V, 50 Hz	240 V, 50 Hz
Consumption	720 W	740 W	716 W	696 W	709 W
Operating current	7.14 A	6.36 A	2.35 A	3.27 A	3.02 A

Power I/O	U.S./Worldwide	UK/Europe
Power input connector	Seetronic Powerkon IP65	Seetronic Powerkon IP65
Power output connector	Seetronic Powerkon IP65	Seetronic Powerkon IP65
Power cord plug	Edison (U.S.)	Local plug

Light Source

Type	Color	Quantity	Power	Current	Lifespan
LED SMD 5050	Tricolor	896	0.784 W	252 mA	50,000 hours
LED	Cool white	432	1.56 W	696 mA	50,000 hours

Photometrics

	Beam Angle	Field Angle	Illuminance @ 5 m
Plate	123°	160°	231 lux
Beam	95° x 50°	138° x 100°	1,432 lux
Plate + Beam	98° x 57°	146° x 122°	1,591 lux

Thermal

Ambient Temperature Range	Cooling System
-4 °F to 113 °F (-20 °C to 45 °C)	Convection

DMX

I/O Connector	Channel Range
5-pin IP65 XLR, Seetronic etherCON IP65	8, 11, 13, 22, 74, 97

Ordering

Product Name	Item Name	Item Code	UPC Number
Color STRIKE M	COLORSTRIKEM	03011799	781462221478



UL 1573
CSA C22.2 No. 166
E113093



RoHS



Contact Us

General Information	Technical Support
Chauvet World Headquarters	
Address: 3360 Davie Rd. Davie, FL 33314 Voice: (954) 577-4455 Fax: (954) 929-5560 Toll Free: (800) 762-1084	Voice: (844) 393-7575 Fax: (954) 756-8015 Email: chauvetcs@chauvetlighting.com Website: www.chauvetprofessional.com
Chauvet U.K.	
Address: Pod 1 EVO Park Little Oak Drive, Sherwood Park Nottinghamshire, NG15 0EB UK Voice: +44 (0) 1773 511115 Fax: +44 (0) 1773 511110	Email: UKtech@chauvetlighting.eu Website: www.chauvetprofessional.eu
Chauvet Benelux	
Address: Stokstraat 18 9770 Kruishoutem Belgium Voice: +32 9 388 93 97	Email: BNLtech@chauvetlighting.eu Website: www.chauvetprofessional.eu
Chauvet France	
Address: 3, Rue Ampère 91380 Chilly-Mazarin France Voice: +33 1 78 85 33 59	Email: FRtech@chauvetlighting.fr Website: www.chauvetprofessional.eu
Chauvet Germany	
Address: Bruno-Bürger-Str. 11 28759 Bremen Germany Voice: +49 421 62 60 20	Email: DEtech@chauvetlighting.de Website: www.chauvetprofessional.eu
Chauvet Mexico	
Address: Av. de las Partidas 34 - 3B (Entrance by Calle 2) Zona Industrial Lerma Lerma, Edo. de México, CP 52000 Voice: +52 (728) 690-2010	Email: servicio@chauvet.com.mx Website: www.chauvetprofessional.mx

Visit the applicable website above to verify our contact information and instructions to request support. Outside the U.S., U.K., Ireland, Benelux, France, Germany, or Mexico, contact the dealer of record.