

# WELL GOBO

WIRELESS EVENT LED LUMINAIRE

## User Manual



## **Edition Notes**

The WELL Gobo User Manual includes a description, safety precautions, installation, programming, operation, and maintenance instructions for the WELL Gobo as of the release date of this edition.

## **Trademarks**

Chauvet, Chauvet Professional, the Chauvet logo, and Well are registered trademarks or trademarks of Chauvet & Sons, LLC (d/b/a Chauvet and Chauvet Lighting) in the United States and other countries. Other company and product names and logos referred to herein may be trademarks of their respective companies.

## **Copyright Notice**

The works of authorship contained in this manual, including, but not limited to, all designs, texts, and images are owned by Chauvet.

© **Copyright 2022 Chauvet & Sons, LLC. All rights reserved.**

Electronically published by Chauvet in the United States of America.

## **Manual Use**

Chauvet authorizes its customers to download and print this manual for professional information purposes only. Chauvet expressly prohibits the usage, copy, storage, distribution, modification, or printing of this manual or its content for any other purpose without written consent from Chauvet.

## **Document Printing**

For best results, print this document in color, on letter size paper (8.5 x 11 in), double-sided. If using A4 paper (210 x 297 mm), configure the printer to scale the content accordingly.

## **Intended Audience**

Any person installing, operating, and/or maintaining this product should completely read through the guide that shipped with the product, as well as this manual, before installing, operating, or maintaining this product.

## **Disclaimer**

Chauvet believes that the information contained in this manual is accurate in all respects. However, Chauvet assumes no responsibility and specifically disclaims any and all liability to any party for any loss, damage, or disruption caused by any errors or omissions in this document, whether such errors or omissions result from negligence, accident, or any other cause. Chauvet reserves the right to revise the content of this document without any obligation to notify any person or company of such revision; however, Chauvet has no obligation to make, and does not commit to make, any such revisions. Download the latest version from [www.chauvetprofessional.com](http://www.chauvetprofessional.com).

## **Document Revision**

This WELL Gobo User Manual is the 4<sup>th</sup> edition of this document. Go to [www.chauvetprofessional.com](http://www.chauvetprofessional.com) for the latest version.

TABLE OF CONTENTS

<b>1. Before You Begin</b> .....	1
What Is Included .....	1
Claims .....	1
Manual Conventions .....	1
Symbols .....	1
FCC Compliance .....	1
Safety Notes .....	2
Personal Safety .....	2
Mounting and Rigging .....	2
Power and Wiring .....	2
Operation .....	2
Expected LED Lifespan .....	2
<b>2. Introduction</b> .....	3
Features .....	3
Product Overview .....	3
Product Dimensions .....	4
<b>3. Setup</b> .....	5
AC Power .....	5
AC Plug .....	5
Replacing the Fuse .....	5
Power Linking .....	5
Battery Charge Notes .....	5
Mounting .....	6
Orientation .....	6
Rigging .....	6
Wireless Operation .....	7
Initial Setup .....	7
Configuration .....	7
Product Pairing .....	7
Storage Notes .....	7
DMX Linking .....	8
DMX Personalities .....	8
Master/Slave Connectivity .....	8
<b>4. Operation</b> .....	9
Control Panel Operation .....	9
Menu Map .....	9
Configuration (DMX) .....	10
Control Personalities .....	10
Starting Address .....	10
Wireless Settings .....	10
DMX Values .....	11
Configuration (Standalone) .....	11
Auto Programs .....	11
Static Mode .....	11
Dimmer Profiles .....	11
LED Frequency .....	11
Back Light .....	11
Control Panel Lock .....	12
System Information .....	12
Factory Reset .....	12
Master/Slave .....	12
<b>5. Technical Information</b> .....	13
Product Maintenance .....	13
<b>6. Technical Specifications</b> .....	14
<b>Returns</b> .....	15
<b>Contact Us</b> .....	16

# 1. Before You Begin

## What Is Included

- 4x WELL Gobo
- Charging case
- Seetronic Powerkon power cord
- Quick Reference Guide

## Claims

Carefully unpack the product immediately and check the container to make sure all the parts are in the package and are in good condition.





If the box or the contents (the product and included accessories) appear damaged from shipping, or show signs of mishandling, notify the carrier immediately, not Chauvet. Failure to report damage to the carrier immediately may invalidate your claim. In addition, keep the box and contents for inspection.

For other issues, such as missing components or parts, damage not related to shipping, or concealed damage, file a claim with Chauvet within 7 days of delivery.

## Manual Conventions

Convention	Meaning
1–512	A range of values
50/60	A set of values of which only one can be chosen
<SET>	A button on the product’s control panel
Settings	A product function or a menu option

## Symbols

Symbol	Meaning
	Electrical warning. Not following these instructions may cause electrical damage to the product, accessories, or the user.
	Critical installation, configuration, or operation information. Not following these instructions may make the product not work, cause damage to the product, or cause harm to the operator.
	Important installation or configuration information. The product may not function correctly if this information is not used.
	Useful information.

 Any reference to data or power connections in this manual assumes the use of Seetronic IP-rated cables.

 The term “DMX” used throughout this manual refers to the USITT DMX512-A digital data transmission protocol.

## FCC Compliance

This device complies with Part 15 Part B of the FCC Rules. Operation is subject to the following two conditions:

1. This device may not cause harmful interference, and
2. This device must accept any interference received, including interference that may cause undesired operation.

Any changes or modifications not expressly approved by the party responsible for compliance could void the user's authority to operate the equipment.

## Before You Begin

---

### Safety Notes

Read all the following safety notes before working with this product. These notes contain important information about the installation, usage, and maintenance of this product.



**This product contains no user-serviceable parts. Any reference to servicing in this User Manual will only apply to properly trained, certified technicians. Do not open the housing or attempt any repairs.**



**All applicable local codes and regulations apply to proper installation of this product.**

### Personal Safety

- Avoid direct eye exposure to the light source while the product is on.
- Always disconnect the product from the power source before cleaning or replacing the fuse.
- Always connect the product to a grounded circuit to avoid the risk of electrocution.
- Do not touch the product's housing when operating because it may be very hot.

### Mounting and Rigging

- Do not submerge this product (IP65). Temporary outdoor operation is fine.
- When using this product in an outdoor environment, use IP65- (or higher) rated power and data cables. Secure unused power and data ports with attached IP65 covers.
- **CAUTION:** When transferring product from extreme temperature environments, (e.g., cold truck to warm, humid ballroom) condensation may form on the internal electronics of the product. To avoid causing a failure, allow product to fully acclimate to the surrounding environment before connecting it to power.
- Not for permanent outdoor installation in locations with extreme environmental conditions. This includes, but is not limited to:
  - Exposure to a marine/saline environment (within 3 miles of a saltwater body of water).
  - Locations where the normal high or low temperatures exceed the temperature ranges in this manual.
  - Locations that are prone to flooding or being buried in snow.
  - Areas where the product will be subjected to extreme radiation or caustic substances.
- Mount this product in a location with adequate ventilation, at least 20 in (50 cm) from adjacent surfaces.
- Make sure there are no flammable materials close to the product when operating.
- When hanging this product, always secure to a fastening device using a safety cable.

### Power and Wiring

- Always make sure you are connecting the product to the proper voltage in accordance with the specifications in this manual or on the product's specification label.
- Never connect the product to a dimmer pack or rheostat.
- Never disconnect this product by pulling or tugging on the power cable.
- It is not recommended to close the road case cover while charging the battery unless the procedure is monitored.

### Operation

- Do not operate this product if there is damage on the housing, lenses, or cables. Have the damaged parts replaced by an authorized technician at once.
- Do not cover the ventilation slots when operating to avoid internal overheating.
- The maximum ambient temperature is 113 °F (45 °C). Do not operate the product at higher temperatures.
- The minimum startup temperature is -4°F (-20°C). Do not start the product at lower temperatures.
- The minimum ambient temperature is -22°F (-30°C). Do not operate the product at lower temperatures.
- In the event of a serious operation problem, stop using this product immediately!



**If your Chauvet product requires service, contact Chauvet Technical Support.**

### Expected LED Lifespan

Over time, use and heat will gradually reduce LED brightness. Clustered LEDs produce more heat than single LEDs, contributing to shorter lifespans if always used at full intensity. The average LED lifespan is 40,000 to 50,000 hours. To extend LED lifespan, maintain proper ventilation around the product, and limit the overall intensity.

## 2. Introduction

The WELL Gobo is a compact, outdoor-ready, battery-operated gobo projector ideal for corporate and event rental inventories. Compatible with both glass and metal gobos, the unit also features a manual 17° to 36° zoom and framing shutters for flawless shutter cuts. Set it then forget it with on-board OLED display, and control your way with WDMX to link to WELL COM. The WELL Gobo includes multiple mounting options and comes in a pack of four with a self-charging case.

### Features

- Operating modes:
  - 1Ch: dimmer
  - 2Ch: 16-bit dimmer
  - 3Ch: 16-bit dimmer and strobe
  - 6Ch: 16-bit dimmer, strobe, auto programs, auto speed, and dimmer speed mode
- A completely wireless, IP65-rated, battery-powered gobo projector with a cool white LED and manual framing shutters that can be controlled by W-DMX, IRC remote (sold separately), or manually from the OLED display
- Zoom range of 17° to 36°, making sizing patterns on surfaces easy
- Hard and soft focuses are easily achieved
- Works with both glass and metal E size gobos (1 mm max thickness)
- User-selectable PWM settings to ensure flawless on-camera operation
- M12 hole for easy clamp installation
- Up to 8 hours of operational time on full charge
- Recharging case can be power linked to save on power outlets
- Recharging case can be charged with the lid closed, saving warehouse space

### Product Overview

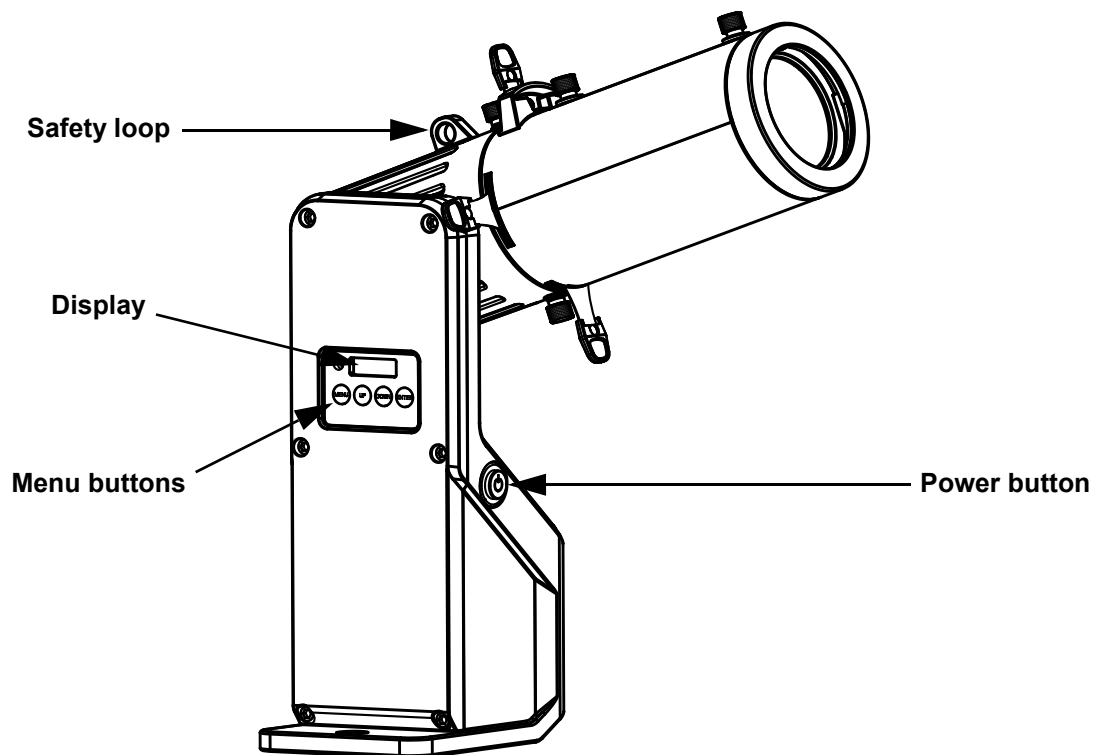

Product Dimensions

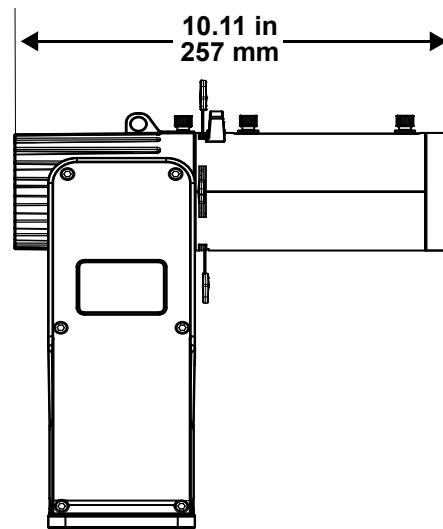
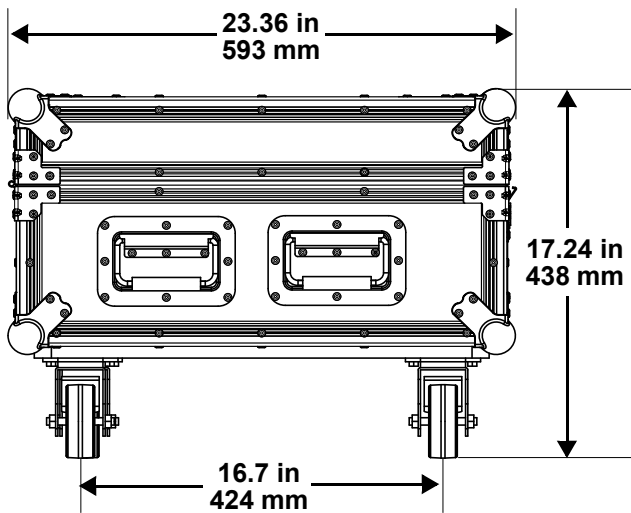
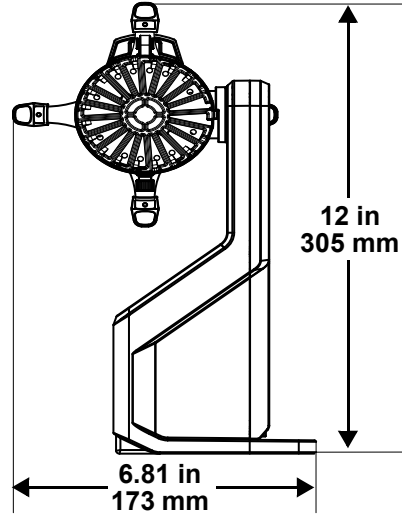
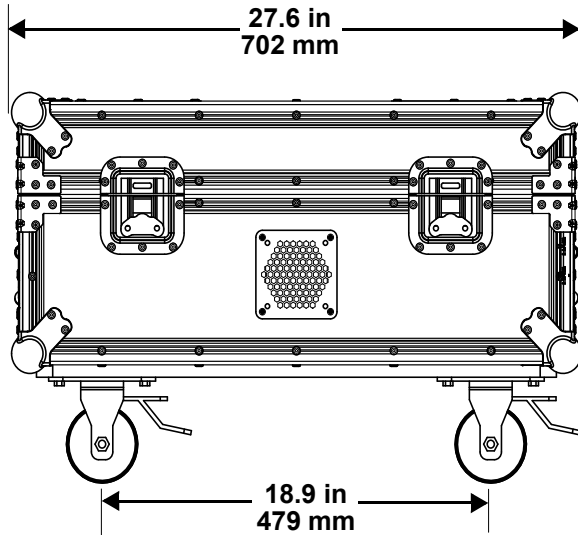

### 3. Setup

#### AC Power

Each WELL Gobo has an auto-ranging battery charger inside the charging case that works with an input voltage range of 100 to 240 VAC, 50/60 Hz. To determine the power requirements for the WELL Gobo, refer to the label affixed to the product or to the [Technical Specifications](#) chart in this manual.

The listed current rating indicates the maximum current draw during normal operation. For more information, download Sizing Circuit Breakers from the Chauvet website: [www.chauvetprofessional.com](http://www.chauvetprofessional.com).



- **Always connect the product to a protected circuit (a circuit breaker or fuse). Make sure the product has an appropriate electrical ground to avoid the risk of electrocution or fire.**
- **Completely disconnect the product from power via breaker or by unplugging it during periods of non-use to eliminate unnecessary wear and improve its lifespan.**
- **Never connect the product to a rheostat (variable resistor) or dimmer circuit, even if the rheostat or dimmer channel serves only as a 0 to 100% switch.**
- **It is not recommended to close the road case cover while charging the battery unless the procedure is monitored.**

#### AC Plug

The WELL Gobo charging case comes with a power input cord terminated with a Seetronic Powerkon connector on one end and an Edison plug on the other end (U.S. market). If the power input cord that came with the product has no plug, or the plug needs to be changed, use the table below to wire the new plug.

Connection	Wire (U.S.)	Wire (Europe)	Screw Color
AC Live	Black	Brown	Yellow or Brass
AC Neutral	White	Blue	Silver
AC Ground	Green/Yellow	Green/Yellow	Green

#### Replacing the Fuse

The WELL Gobo has no external fuse. However, the charging case comes with a replaceable fuse.

1. Disconnect the product from power.
2. Using a flat-head screwdriver, unscrew the fuse holder cap from the housing.
3. Remove the blown fuse and replace with a good fuse of the same type and rating.
4. Screw the fuse holder cap back in place and reconnect power.

#### Power Linking

It is possible to power link multiple charging cases and charge up to 7 WELL Gobo products at 100 V, 8 products at 120 V, 16 products at 208 V, 18 products at 230 V, or up to 19 products at 240 V at the same time. Never exceed this number. Power linking cords can be purchased separately.

#### Battery Charge Notes

This product is equipped with a built-in rechargeable lithium ion battery.

- Avoid depleting the battery below 10%.
- For best results, charge the battery in a temperature between 32 °F (0 °C), and 95 °F (35 °C).
- When charging the battery, keep the product at least 1 m from any open flame or hot plate.
- If the battery is completely discharged, the device cannot be turned on immediately when the charger is connected. Allow a depleted battery to charge for a few minutes before turning on the device.
- The device may heat up while charging. This is normal and should not affect the device's lifespan or performance. If the battery gets hotter than usual, the charger may stop charging.
- When charging the battery, keep the road case's cover open.
- Always charge the battery with the product in an upright position.
- Do not charge the battery for more than 24 hours.

Battery charge time	Battery life (high output)	Battery life (power-saving mode)
8 hours	5 hours	8 hours



## Setup

### Mounting

Before mounting the product, read and follow the safety recommendations indicated in the [Safety Notes](#). For our CHAUVET Professional line of mounting clamps, go to <http://trusst.com/products/>.

### Orientation

Always mount this product in a safe position, making sure there is adequate room for ventilation, configuration, and maintenance.

### Rigging

Chauvet recommends using the following general guidelines when mounting this product.

- Before deciding on a location for the product, make sure there is easy access to the product for maintenance and programming purposes.
- Ensure that the structure onto which the product will be mounted can support the product's weight. See the [Technical Specifications](#) for weight information.
- When mounting the product overhead, always use a safety cable. Mount the product securely to a rigging point, whether an elevated platform or a truss.
- When rigging the product onto a truss, use a mounting clamp of appropriate weight capacity.
- When power linking multiple products, mount the products close enough for power-linking cables to reach.
- The bracket adjustment knobs allow for directional adjustment when aiming the product to the desired angle. Only loosen or tighten the bracket knobs manually. Using tools could damage the knobs.

### Mounting diagram

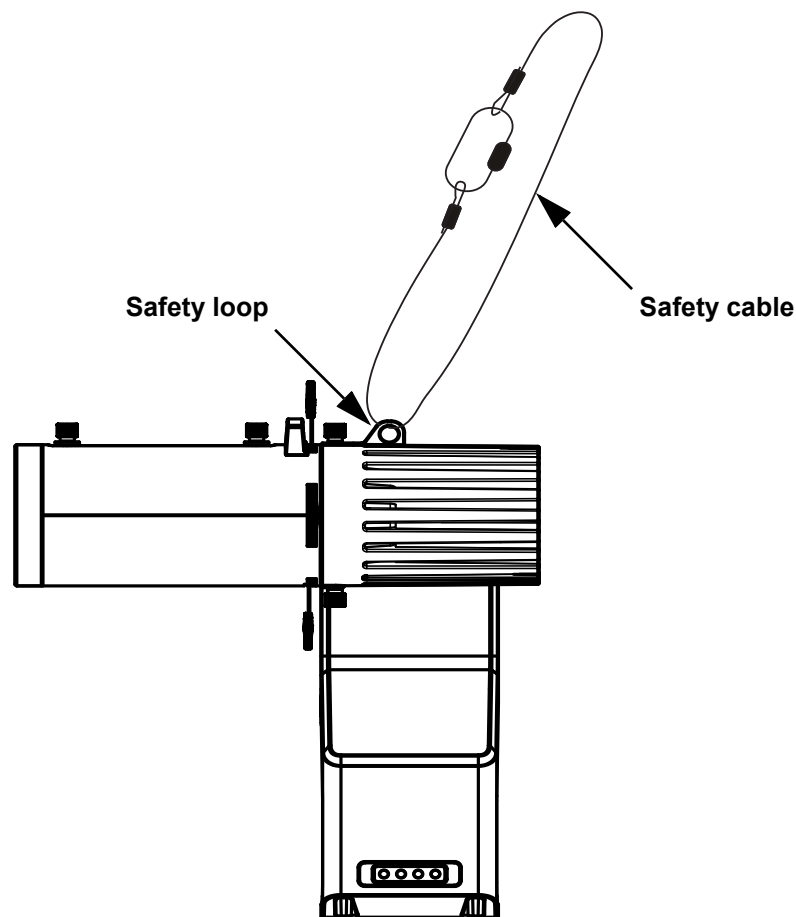

## Wireless Operation

In optimal conditions, the WELL Gobo can operate up to 300 m (900 ft) away from the W-DMX transmitter. The W-DMX receiver in the WELL Gobo must be paired with the W-DMX transmitter for wireless operation.



**Once a WDMX receiver has been linked to a specific WDMX transmitter, it will remain linked to that specific transmitter until it is linked to a different one.**

### Initial Setup

1. Turn the W-DMX transmitter on.
2. Connect the W-DMX transmitter to a DMX controller.
3. Place the WELL Gobo within 300 m from the W-DMX transmitter.
4. Turn the WELL Gobo on.

### Configuration

1. From the WELL Gobo control panel, go to **DMX Address**.
2. Select the start address, as with any other DMX-compatible product.
3. Go to **Wireless Setting > Receive**.
4. Select **Receive**.
5. Select **On**. (The Signal Strength Indicator will show a ? in front of the bars).
6. Press the reset button on the W-DMX transmitter.  
(The Signal Strength Indicator on the WELL Gobo will show a ⚡ in front of the bars for 3 seconds while a connection is established.)

### Product Pairing

If the WELL Gobo has already been paired with the W-DMX transmitter, the Signal Strength Indicator in the middle of the LCD screen will show the strength of the signal. In this case, the WELL Gobo is ready to work in Wireless mode.

#### Pairing the WELL Gobo and a new W-DMX transmitter:

1. From the WELL Gobo control panel, go to **Wireless Setting > Receive Reset**.
2. Select **Yes**. The Signal Strength Indicator on the WELL Gobo will show a ? in front of the bars.
3. From the W-DMX transmitter, press **<RESET>** (the Signal Indicator on the transmitter will flash).
4. Once the transmitter has found the WELL Gobo, the Signal indicator on the W-DMX transmitter will illuminate solid.
5. The Signal Strength Indicator in the middle of the LCD screen on the WELL Gobo will show the strength of the signal.



**W-DMX operation can be interrupted or inhibited by liquid masses between the transmitter and receiver such as water, snow, or people. For best results, keep the area between the transmitter and receiver clear of any liquid mass.**

### Storage Notes

- Store charged product(s) in a dry environment, away from direct sunlight.
- Charge or discharge the battery to approximately 50% of capacity before storage.
- Lithium-Ion batteries continue to slowly discharge (self-discharge) when not in use or while in storage. Routinely check the battery's charge status
- Store the battery at temperatures between 41 °F and 68 °F (5 °C and 20 °C).

## DMX Linking

You can link the WELL Gobo to a DMX controller using a wireless DMX connection. If using other DMX-compatible products with this product, each can be controlled individually with a single DMX controller.

### DMX Personalities

The WELL Gobo uses a wireless DMX data connection for the **1Ch**, **2Ch**, **3Ch**, and **6Ch** DMX personalities.

- Refer to the [Introduction](#) chapter for a brief description of each DMX personality.
- Refer to the [Operation](#) chapter to learn how to configure the WELL Gobo to work in these personalities.
- The [Configuration \(Standalone\)](#) section provides detailed information regarding the control personalities.



For more information about DMX standards, Master/Slave connectivity, or the DMX cables needed to link this product to a DMX controller, download the DMX Primer from the Chauvet website: [www.chauvetprofessional.com](http://www.chauvetprofessional.com).

### Master/Slave Connectivity

The Master/Slave mode allows a WELL Gobo (the master) to control one or more WELL Gobo products (the slaves) without a DMX controller. One WELL Gobo becomes the master when running an auto program or by being in Static mode.

You must configure each slave's control panel to operate in Slave mode. During Master/Slave operation, the slaves will operate in unison with the master.



**DO NOT connect a DMX controller to products operating in Master/Slave mode. The DMX controller signals may interfere with the signals from the master.**



- The [Operation](#) section of this manual provides detailed instructions on how to configure the master and slaves.
- For more information about DMX standards or the DMX cables needed to link this product to a DMX controller, download the DMX Primer from the Chauvet website: [www.chauvetprofessional.com](http://www.chauvetprofessional.com).

## 4. Operation

### Control Panel Operation

Button	Function
<MENU>	Exits from the current menu or function
<ENTER>	Enables the currently displayed menu or sets the currently selected value in to the current function
<UP>	Navigates upward through the menu list or increases the numeric value when in a function
<DOWN>	Navigates downward through the menu list or decreases the numeric value when in a function

### Menu Map

Refer to the WELL Gobo product page on [www.chauvetprofessional.com](http://www.chauvetprofessional.com) for the latest menu map.

Main Level	Programming Levels		Description
DMX Address	1–511		Selects DMX address (highest channel restricted to personality chosen)
DMX Channel	1Ch		1-channel: dimmer
	2Ch		2-channel: 16-bit dimmer
	3Ch		3-channel: 16-bit dimmer and strobe
	6Ch		6-channel: 16-bit dimmer, strobe, auto programs, auto speed, and dimmer speed mode
Static	Dimmer	0–255	Dimmer mode
	Strobe		Strobe mode
Auto Show	Auto 1	1–100	Automatic programs
	Auto 2		
	Auto 3		
	Auto 4		
Master/Slave	Master		Master mode (standalone)
	Slave		Slave mode (DMX)
Wireless Setting	Receive	On	Sets the WELL Gobo to receive signal
		Off	
	Reset	No	Resets the wireless setting
		Yes	
IR Setting	On		Enables/disables IR receiver
	Off		
Run time	Off		Shows the unit's total run time
	8 hours		
Dimmer Mode	Off		Dimmer mode off
	Dimmer 1		
	Dimmer 2		
	Dimmer 3		
LED Frequency	250Hz		Sets the LED frequency
	600Hz		
	1200Hz		
	2000Hz		
	4000Hz		
	6000Hz		

## Operation

Main Level	Programming Levels	Description
Back Light	Always on	Display backlight always on
	10S	Turns off display backlight after 10 seconds of inactivity
	30S	Turns off display backlight after 30 seconds of inactivity
	2Min	Turns off display backlight after 2 minutes of inactivity
Key Lock	On	Locks display (password is <UP>, <DOWN>, <UP>, <DOWN>, <ENTER>)
	Off	
Information	Fixture hours	___H
	Version	V_._
Reset Factory	No	Resets the product to factory default settings
	Yes	

## Configuration (DMX)

Use control configurations to operate the product with a DMX controller. For information on how to configure wireless DMX, see [DMX Linking](#).

### Control Personalities

This setting allows you to choose a particular control personality.

1. Go to the **DMX Channel** main level.
2. Select the desired personality (see table below).

Personality	Channels
6Ch	6 channels
3Ch	3 channels
2Ch	2 channels
1Ch	1 channels



- See the [Starting Address](#) section for the highest starting address you can select for each personality.
- Make sure that the starting addresses on the various products do not overlap due to the new personality setting.

### Starting Address

Each product will respond to a unique starting address from the DMX controller. All products with the same starting address will respond in unison.

1. Go to the **DMX Address** main level.
2. Select the starting address (**001–511**).

The highest recommended starting address for each DMX mode is as follows:

Personality	Address
6Ch	506
3Ch	509
2Ch	510
1Ch	511

### Wireless Settings

This mode allows the user to control the DMX wirelessly. For detailed setup of this feature, see [Wireless Operation](#). To disable this feature:

1. Go to **Wireless Setting > Receive**.
2. Select **Off**.



Once a WDMX receiver has been linked to a specific WDMX transmitter, it will remain linked to that specific transmitter until it is linked to a different one.

## DMX Values

1Ch	2Ch	3Ch	6Ch	Function	Value	Percent/Setting
1	1	1	1	<b>Dimmer</b>	000 ⇔ 255	0–100%
–	2	2	2	<b>Dimmer fine</b>	000 ⇔ 255	0–100%
–	–	3	3	<b>Strobe</b>	000 ⇔ 010 011 ⇔ 255	No function Strobe, slow to fast
–	–	–	4	<b>Auto programs</b>	000 ⇔ 070 071 ⇔ 130 131 ⇔ 190 191 ⇔ 255	No function Auto program 1 Auto program 2 Auto program 3
–	–	–	5	<b>Auto speed</b>	000 ⇔ 255	Auto speed, slow to fast
–	–	–	6	<b>Dimmer speed mode</b>	000 ⇔ 051 052 ⇔ 101 102 ⇔ 152 153 ⇔ 203 204 ⇔ 255	Preset dimmer speed from display menu Dimmer speed mode off Dimmer speed mode 1 (fastest) Dimmer speed mode 2 Dimmer speed mode 3 (slowest)

## Configuration (Standalone)

Use standalone configuration to operate the product without a DMX controller.

### Auto Programs

Auto programs allow for dynamic blinder effects without a DMX controller.

1. Go to the **Auto Show** main level.
2. Select the desired auto program (**Auto 1–4**).
3. Select the desired speed (**1–100**).



**The auto programs cannot be edited.**

### Static Mode

The Static mode allows for permanent dimmer and strobe presets without a DMX controller.

1. Go to the **Static** main level.
2. Select **Dimmer** or **Strobe**.
3. Set the desired output value (**0–255**).

### Dimmer Profiles

This setting determines how fast the output of the WELL Gobo changes when you modify the output value. This setting provides four different options to simulate the dimming curve of an incandescent lighting product.

1. Go to the **Dimmer Mode** main level.
2. Select a dimmer curve (**Off**, **Dimmer 1**, **Dimmer 2**, or **Dimmer 3**).



**Off:** The output is proportional (linear) to the dimmer channel value.

**Dimmer 1-3:** The output follows the dimmer value based on the corresponding dimmer curve, **Dimmer 1** being the fastest.

### LED Frequency

This option changes the Pulse Width Modulation (PWM) frequency of the LEDs on the WELL Gobo.

1. Go to the **LED Frequency** main level.
2. Select PWM Frequency (**25Hz**, **600Hz**, **1200Hz**, **2000Hz**, **4000Hz**, or **6000Hz**).

### Back Light

This setting allows for selection of the amount of time the backlight on the WELL Gobo's display stays on after the last button is pressed on the control panel.

1. Go to the **Back Light** main level.
2. Select **10S** (10 seconds), **30S** (30 seconds), **2Min** (2 minutes), or **Always On** (remains on).

## Operation

---

### Control Panel Lock

This setting locks or unlocks the display control panel.

1. Go to the **Key Lock** main level.
2. Select **On** (locks control panel) or **Off** (control panel stays unlocked).



**When the control panel lock is activated, the product will prompt for the passcode to access the menu. Enter the passcode by pressing: <UP>, <DOWN>, <UP>, <DOWN>, <ENTER>**

### System Information

This option displays the total number of hours the product has run, the installed software version, and the product's UID.

1. Go to the **Information** main level.
2. Select **Fixture Hours** or **Version**.

### Factory Reset

This option restores the WELL Gobo to factory default settings.

1. Go to the **Reset Factory** main level.
2. Select **No** or **Yes**.

### Master/Slave

The Master/Slave mode allows a group of WELL Gobo products (the slaves) to simultaneously duplicate the output of another WELL Gobo (the master) without a DMX controller. To set each of the slaves:

1. Go to the **Master/Slave** main level.
2. Select **Slave**.
3. Go to **Wireless Setting > Receive**.
4. Select **On**.

To set the master:

1. Go to the **Master/Slave** main level.
2. Select **Master**.
3. Select a standalone setting or control with the IR remote.



- **The master is the one that runs a program whether in Auto, Static, or IR mode.**
- **Do not connect a DMX controller to the products configured for Master/Slave operation. The DMX controller may interfere with signals from the master.**
- **Do not connect a WDMX transmitter to the products configured for Master/Slave operation. The WDMX transmitter may interfere with signals from the master.**

## 5. Technical Information

### Product Maintenance

To maintain optimum performance and minimize wear, clean this product frequently. Usage and environment are contributing factors in determining the cleaning frequency.

Clean this product at least twice a month. Dust build-up reduces light output performance and can cause overheating. This can lead to reduced light source life and increased mechanical wear.

To clean the product:

1. Unplug the product from power and switch off.
2. Wait until the product is at room temperature.
3. Use a vacuum (or dry compressed air) and a soft brush to remove dust collected on the external vents.
4. Clean all transparent surfaces with a mild soap solution, ammonia-free glass cleaner, or isopropyl alcohol.
5. Apply the solution directly to a soft, lint-free cotton cloth or a lens-cleaning tissue.
6. Softly drag any dirt or grime to the outside of the transparent surface.
7. Gently polish the transparent surfaces until they are free of haze and lint.



**Always dry the transparent surfaces carefully after cleaning them.**



## Technical Specifications

### 6. Technical Specifications

#### Dimensions and Weight

	Length	Width	Height	Weight
<b>WELL Gobo</b>	10.11 in (257 mm)	6.81 in (173 mm)	12 in (305 mm)	6.6 lb (3 kg)
<b>Charging Case</b>	27.64 in (702 mm)	17.24 in (438 mm)	23.36 in (593.4 mm)	71 lb (32.21 kg)

**Note:** Dimensions in inches are rounded.

#### Power

Power Supply Type	Range	Voltage Selection
Switching (internal)	100 to 240 VAC, 50/60 Hz	Auto-ranging

Parameter	100 V, 60 Hz	120 V, 60 Hz	208 V, 60 Hz	230 V, 50 Hz	240 Hz, 50 V
Consumption (single)	42 W	42 W	38 W	40 W	39 W
Operating current (single product charging)	0.436 A	0.362 A	0.220 A	0.215 A	0.211 A
Consumption (charging case)	155 W	153 W	147 W	144 W	143 W
Operating current (charging case)	1.537 A	1.386 A	0.719 A	0.663 A	0.629 A
Power linking (products)	12 A (7 products)	12 A (8 products)	12 A (16 products)	12 A (18 products)	12 A (19 products)
Fuse (charging case)	T 3.15A 250V	T 3.15A 250V	T 3.15A 250V	T 3.15A 250V	T 3.15A 250V

Power I/O	U.S./Worldwide	UK/Europe
Power input connector	Seetronic Powerkon	Seetronic Powerkon
Power output connector	Seetronic Powerkon	Seetronic Powerkon
Power cord plug	Edison (U.S.)	Local plug

#### Light Source

Type	Color	Quantity	Power	Current	Lifespan
LED	Cool white	1	25.2 W	1.3 A	50,000 hours

#### Photometrics

Beam Angle	Field Angle	Zoom Angle	
17.3° to 36.6°	20° to 41°	20° to 41°	
Illuminance @ 5 m (17.3°)	Illuminance @ 5 m (8 hr mode 17.3°)	Illuminance @ 5 m (36.6°)	Illuminance @ 5 m (P/S mode 36.6°)
1,487 lux	1,487 lux	347 lux	165 lux

#### Thermal

Maximum External Temperature	Cooling System
113 °F (45 °C)	Convection

#### DMX

I/O Connector	Channel Range
Wireless	1, 2, 3, or 6 channels

#### Ordering

Product Name	Item Name	Item Code	UPC Number
WELL Gobo	WELLGOBOBOX4	03031662	81462220105



## Returns

Send the product prepaid, in the original box, and with the original packing and accessories. Chauvet will not issue call tags.

Call Chauvet and request a Return Merchandise Authorization (RMA) number before shipping the product. Be prepared to provide the model number, serial number, and a brief description of the cause(s) for the return.

To submit a service request online, go to [www.chauvetprofessional.com/service-request](http://www.chauvetprofessional.com/service-request).

Clearly label the package with an RMA number. Chauvet will refuse any product returned without an RMA number.



**Write the RMA number on a properly affixed label. DO NOT write the RMA number directly on the box.**

Once you have the RMA number, provide the following information on a piece of paper and place it inside the box:

- Your name
- Your address
- Your phone number
- RMA number
- A brief description of the problem

Be sure to pack the product properly. Any shipping damage resulting from inadequate packaging will be your responsibility. FedEx packing or double-boxing are recommended.



**Chauvet reserves the right to use its own discretion to repair or replace returned product(s).**

## Contact Us

General Information	Technical Support
<b>Chauvet World Headquarters</b>	
Address: 5200 NW 108th Ave. Sunrise, FL 33351 Voice: (954) 577-4455 Fax: (954) 929-5560 Toll Free: (800) 762-1084	Voice: (844) 393-7575 Fax: (954) 756-8015 Email: <a href="mailto:chauvetcs@chauvetlighting.com">chauvetcs@chauvetlighting.com</a> Website: <a href="http://www.chauvetprofessional.com">www.chauvetprofessional.com</a>
<b>Chauvet U.K.</b>	
Address: Unit 1C Brookhill Road Industrial Estate Pinxton, Nottingham, UK NG16 6NT Voice: +44 (0) 1773 511115 Fax: +44 (0) 1773 511110	Email: <a href="mailto:UKtech@chauvetlighting.eu">UKtech@chauvetlighting.eu</a> Website: <a href="http://www.chauvetprofessional.eu">www.chauvetprofessional.eu</a>
<b>Chauvet Benelux</b>	
Address: Stokstraat 18 9770 Kruishoutem Belgium Voice: +32 9 388 93 97	Email: <a href="mailto:BNLtech@chauvetlighting.eu">BNLtech@chauvetlighting.eu</a> Website: <a href="http://www.chauvetprofessional.eu">www.chauvetprofessional.eu</a>
<b>Chauvet France</b>	
Address: 3, Rue Ampère 91380 Chilly-Mazarin France Voice: +33 1 78 85 33 59	Email: <a href="mailto:FRtech@chauvetlighting.fr">FRtech@chauvetlighting.fr</a> Website: <a href="http://www.chauvetprofessional.eu">www.chauvetprofessional.eu</a>
<b>Chauvet Germany</b>	
Address: Bruno-Bürgel-Str. 11 28759 Bremen Germany Voice: +49 421 62 60 20	Email: <a href="mailto:DEtech@chauvetlighting.de">DEtech@chauvetlighting.de</a> Website: <a href="http://www.chauvetprofessional.eu">www.chauvetprofessional.eu</a>
<b>Chauvet Mexico</b>	
Address: Av. de las Partidas 34 - 3B (Entrance by Calle 2) Zona Industrial Lerma Lerma, Edo. de México, CP 52000 Voice: +52 (728) 690-2010	Email: <a href="mailto:servicio@chauvet.com.mx">servicio@chauvet.com.mx</a> Website: <a href="http://www.chauvetprofessional.mx">www.chauvetprofessional.mx</a>

Visit the applicable website above to verify our contact information and instructions to request support. Outside the U.S., U.K., Ireland, France, Germany, Benelux, or Mexico, contact the dealer of record.