

Vesuvio *RGBA*

User Manual

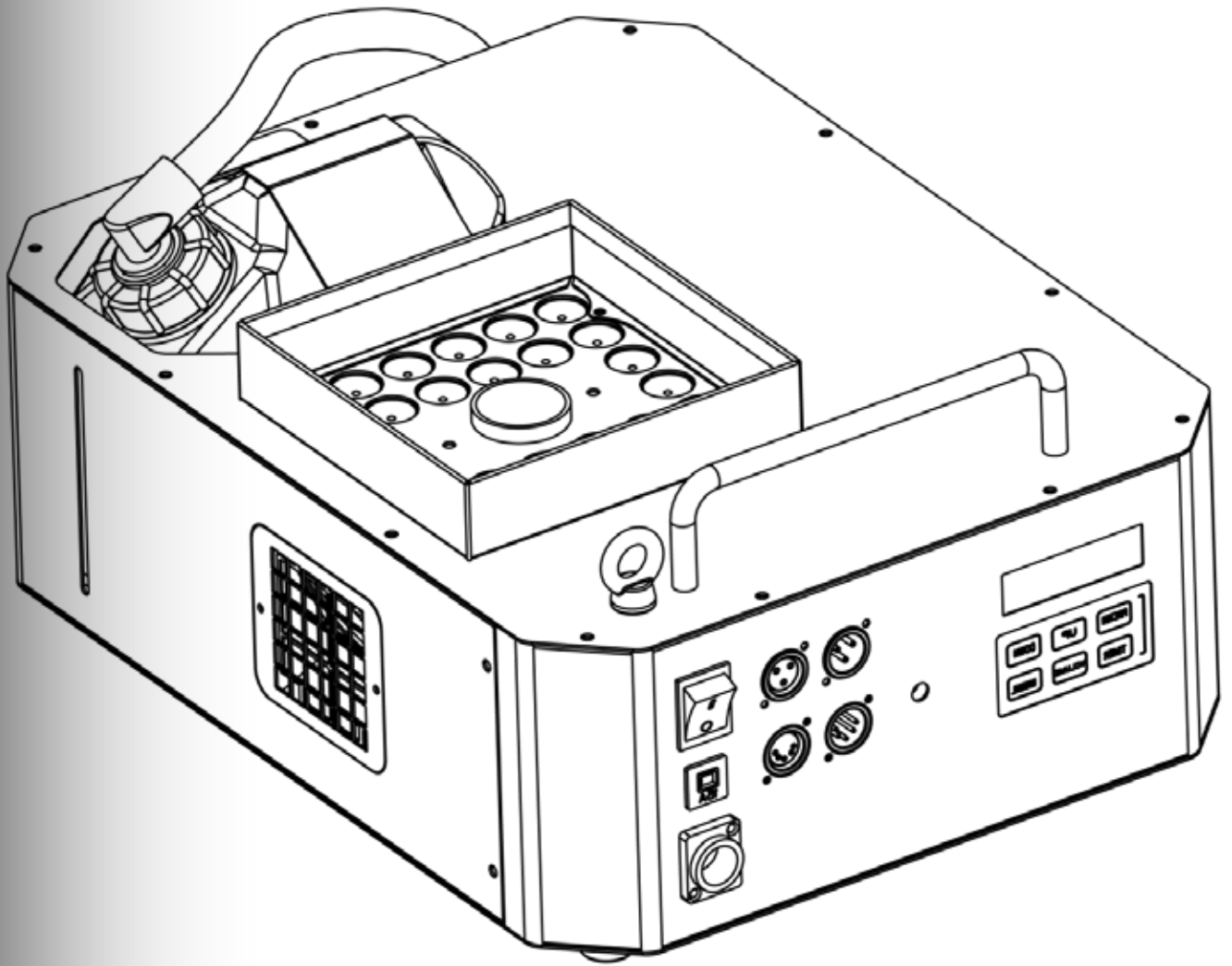

CHAUVET
PROFESSIONAL

Edition Notes The Vesuvio RGBA User Manual Rev. 4 covers the description, safety precautions, installation, programming, operation, and maintenance of the Vesuvio RGBA. Chauvet released this edition of the Vesuvio RGBA User Manual in May 2017.

Trademarks CHAUVET, the Chauvet logo and Vesuvio RGBA are registered trademarks or trademarks of Chauvet & Sons, LLC (d/b/a Chauvet and Chauvet Lighting) in the United States and other countries. Other company and product names and logos referred to herein may be trademarks of their respective companies.

Copyright Notice Chauvet owns the content of this User Manual in its entirety, including but not limited to pictures, logos, trademarks, and resources.

© **Copyright 2017 Chauvet. All rights reserved.**

Electronically published by Chauvet in the United States of America.

Manual Use Chauvet authorizes its customers to download and print this manual for professional information purposes only. Chauvet expressly prohibits the usage, copy, storage, distribution, modification, or printing of this manual or its content for any other purpose without written consent from Chauvet.

Document Printing For better results, print this document in color, on letter size paper (8.5 x 11 in), double-sided. If using A4 paper (210 x 297 mm), configure your printer to scale the content accordingly.

Intended Audience Any person in charge of installing, operating, and/or maintaining this product should completely read through the guide that shipped with the product, as well as this manual, before installing, operating, or maintaining this product.

Disclaimer Chauvet believes that the information contained in this manual is accurate in all respects. However, Chauvet assumes no responsibility and specifically disclaims any and all liability to any party for any loss, damage or disruption caused by any errors or omissions in this document, whether such errors or omissions result from negligence, accident or any other cause. Chauvet reserves the right to revise the content of this document without any obligation to notify any person or company of such revision, however, Chauvet has no obligation to make, and does not commit to make, any such revisions.

Document Revision The Vesuvio RGBA User Manual Rev. 4 supersedes all previous versions of this manual. Discard any older versions of this manual and replace with this version. Go to www.chauvetprofessional.com for the latest version.

Table of Contents

- 1. Before You Begin 1**
 - What Is Included 1
 - Claims 1
 - Manual Conventions 1
 - Symbols 1
 - Safety Notes 1
 - Personal Safety 2
 - Mounting And Rigging 2
 - Power And Wiring 2
 - Operation 2
 - Expected LED Lifespan 2
- 2. Introduction 3**
 - Description 3
 - Features 3
 - Overview 4
 - Dimensions 5
- 3. Setup 6**
 - AC Power 6
 - AC Plug 6
 - Resetting the Breaker 6
 - DMX Linking 6
 - DMX Personalities 6
 - Mounting 7
 - Orientation 7
 - Rigging 7
 - Procedure 7
 - Tank Inversion 8
- 4. Operation 9**
 - Control Panel Description 9
 - Control Options 9
 - Programming 9
 - Preparing for Operation 9
 - Startup 9
 - Menu Map 10
 - DMX Values 10
 - DMX Values (Cont.) 11
 - DMX Values (Cont.) 12
 - DMX Values (Cont.) 13
 - Starting Address 14
 - Setting the LED Color 14
 - Timer Mode 14
 - Manual Mode 14
 - Timer Mode Parameters 14
- 5. Technical Information 15**
 - Maintenance 15
 - Storage 15
- 6. Technical Specifications 16**
 - Returns 17
- Contact Us 17**

1. BEFORE YOU BEGIN



- What Is Included**
- Vesuvio RGBA
 - Neutrik® powerCON® power cord
 - Warranty Card
 - Quick Reference Guide

Claims Carefully unpack the product immediately and check the box to make sure all the parts are in the package and are in good condition. If the box or the contents (the product and included accessories) appear damaged from shipping or show signs of mishandling, notify the carrier immediately, not Chauvet. Failure to report damage to the carrier immediately may invalidate your claim. In addition, keep the box and contents for inspection. For other issues, such as missing components or parts, damage not related to shipping, or concealed damage, file a claim with Chauvet within 7 days of delivery.

Manual Conventions

Convention	Meaning
1–512	A range of values in the text
50/60	A set of mutually exclusive values in the text
<SET>	A button on the product’s control panel
Settings	A product function or a menu option
MENU>Settings	A sequence of menu options
1–10	A range of menu values from which to choose in a menu
Yes/No	A set of two mutually exclusive menu options in a menu
ON	A unique value to be entered or selected in a menu

Symbols

Symbols	Meaning
	Critical installation, configuration, or operation information. Failure to comply with this information may cause the product not to work, damage third-party equipment, or cause harm to the operator.
	Important installation or configuration information. Failure to comply with this information may keep the product from working.
	Useful information.



The term “DMX” used throughout this manual refers to the USITT DMX512-A digital data transmission protocol.

Safety Notes

Read all the following Safety Notes before working with this product. These notes include important information about the installation, usage, and maintenance of this product.



This product contains no user-serviceable parts. Any reference to servicing in this User Manual will only apply to properly trained Chauvet certified technicians. Do not open the housing or attempt any repairs.



All applicable local codes and regulations apply to proper installation of this product.

Personal Safety

- Avoid direct eye exposure to the light source while the product is on.
- Always disconnect this product from its power source before servicing.
- Always connect this product to a grounded circuit to avoid the risk of electrocution.
- The product’s nozzle is very hot during operation and it remains hot for a long time after operation has stopped.
- The fog exits the nozzle at a very high temperature. Keep a minimum distance of 6.5 ft (2 m) from the nozzle to the nearest object.
- Do not use the product as a space heater.
- Do not drink or become in contact with the fog fluid. If you do, call your local emergency service (911 in the US) for help.
- Do not add perfume, alcohol, gasoline, or any other flammables to the fog fluid. Do not touch this product’s housing during operation because it may be very hot.

Mounting And Rigging

- The product is for indoor use only! (IP20) To prevent risk of fire or shock, do not expose the product to rain or moisture.
- Mount this product in a location with adequate ventilation, at least 20 in (50 cm) from adjacent surfaces.
- Make sure there are no flammable materials close to this product while it is operating.
- When hanging this product, always secure to a fastening device using a safety cable.

Power And Wiring

- Always make sure you are connecting this product to the proper voltage in accordance with the specifications in this manual or on the product’s specification label.
- To eliminate unnecessary wear and improve its lifespan, during periods of non-use completely disconnect the product from power via breaker or by unplugging it.
- CAUTION: When transferring product from extreme temperature environments, (e.g. cold truck to warm humid ballroom) condensation may form on the internal electronics of the product. To avoid causing a failure, allow product to fully acclimate to the surrounding environment before connecting it to power.

Operation

- Never connect this product to a dimmer pack or rheostat.
- Make sure the power cord is not crimped or damaged.
- Never disconnect this product by pulling or tugging on the power cable.
- Make sure there is adequate fog fluid in the machine to prevent pump and heater damage.
- Never carry the product by the power cord or any moving part. Always use the handles.
- Do not operate this product if you see damage on the housing, lenses, or cables. Have the damaged parts replaced by an authorized technician at once.
- You may hear a loud popping sound during operation. This is normal.
- Do not cover the ventilation slots when operating to avoid internal overheating.
- The maximum ambient temperature is 104 °F (40 °C). Do not operate this product at a higher temperature.
- Never try to repair the product. Repairs carried out by unskilled people can lead to damage or malfunction. Contact the nearest authorized technical assistance center.
- This product is not intended for permanent installation.
- Use only CHAUVET water-based (QDF) fog fluid.
- Drain the tank before transporting the product.
- In case of a serious operating problem, stop using this product immediately!



In the unlikely event that your Chauvet product may require service, contact Chauvet Technical Support.

Expected LED Lifespan

LEDs gradually decline in brightness over time, primarily due to heat. Packaged in clusters, LEDs exhibit higher operating temperatures than in ideal, single-LED conditions. For this reason, using clustered LEDs at their fullest intensity significantly reduces the LEDs’ lifespan. Under normal conditions, this lifespan can be 40,000 to 50,000 hours. If extending this lifespan is vital, lower the operating temperature by improving the ventilation around the product and reducing the ambient temperature to an optimal operating range. In addition, limiting the overall projection intensity may also help to extend the LEDs’ lifespan.

2. INTRODUCTION

Description The Vesuvio RGBA atmospheric effect generator allows you to add red, green, blue, and amber color mixing (RGBA) to fog output for a multicolor atmospheric column. Vesuvio RGBA features a quick heating 1.6 kW heater, a 2.5 liter fluid tank, and features a 40,000 cubic feet per minute (cfm) output.

- Features**
- Advanced red, green, blue, and amber (RGBA) LED color mixing
 - 40,000 cfm fog output for intense, large effects
 - 2.5 l fluid tank for reliability in production
 - 1.6 kW fluid heater for voluminous, heavy bursts of fog
 - Strong, sturdy construction for numerous production types
 - DMX control for ease of use in production situations
 - 3- and 5-pin DMX input/output connections

Overview

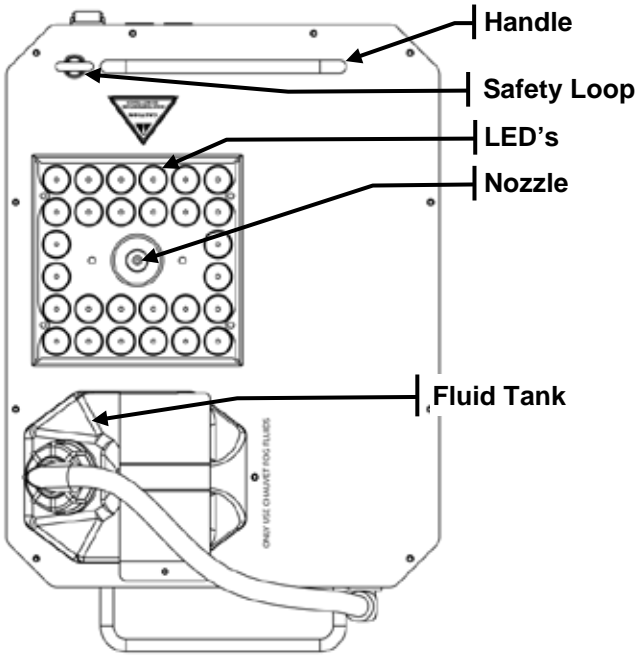

Top View

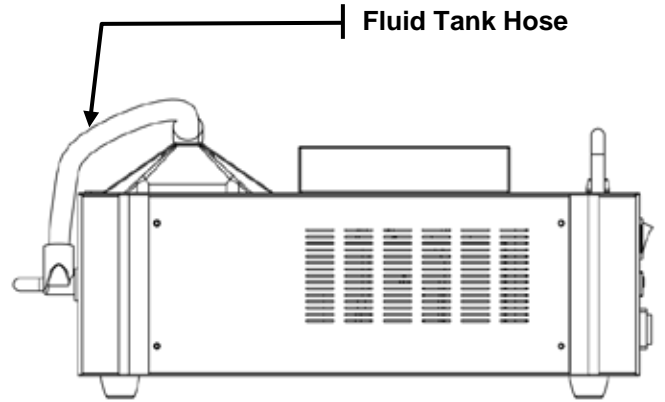

Side View

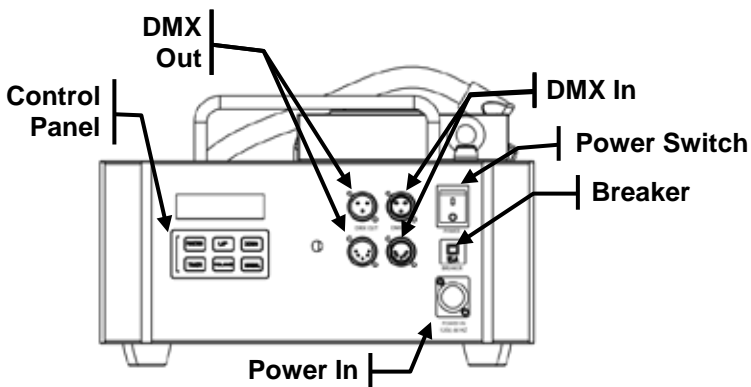

Rear View

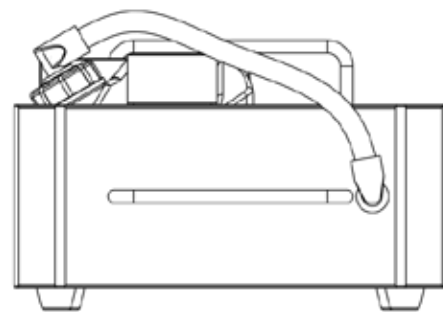

Front View

Dimensions

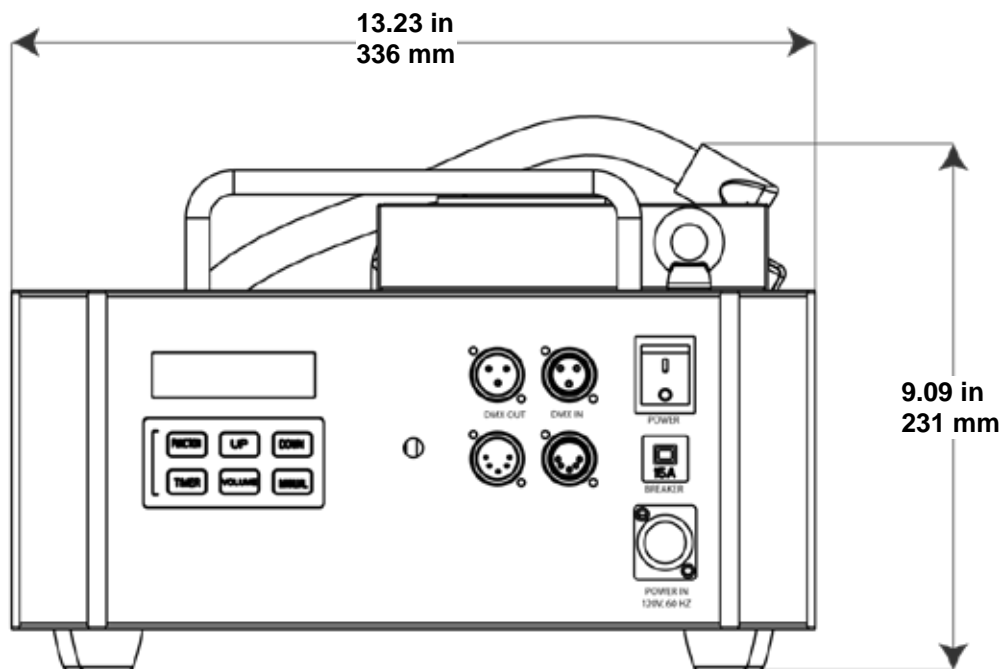
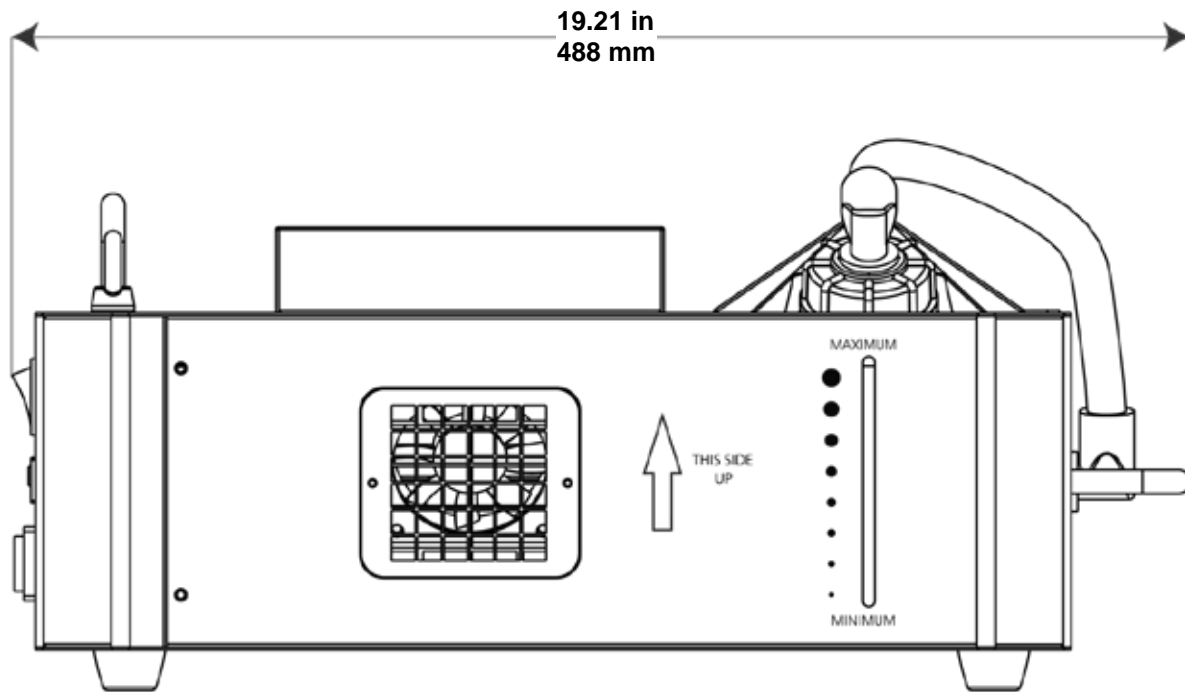

3. SETUP

AC Power

Each Vesuvio RGBA has a fixed power supply that works with an input voltage of 120 VAC, 60 Hz. To determine the power requirements for each Vesuvio RGBA, refer to the label affixed to the product. You can also refer to the [Technical Specifications](#) chart in this manual.

The listed current rating indicates the maximum current draw during normal operation. For more information, you may download Sizing Circuit Breakers from the Chauvet website www.chauvetlighting.com/download/pro.



Always connect this product to a protected circuit with an appropriate electrical ground to avoid the risk of electrocution or fire.



Never connect this product to a rheostat (variable resistor) or dimmer circuit, even if the rheostat or dimmer channel serves only as a 0 to 100% switch.

AC Plug

The Vesuvio RGBA comes with a power input cord terminated with a Neutrik® powerCON® A connector on one end and an Edison plug on the other end (U.S. market). If the power input cord that came with your product has no plug, or if you need to change the Edison plug, use the table below to wire the new plug to the power input cord.

Connection	Wire (U.S.)	Wire (Europe)	Screw Color
AC Live	Black	Brown	Yellow or Brass
AC Neutral	White	Blue	Silver
AC Ground	Green/Yellow	Green/Yellow	Green

Resetting the Breaker

This product is equipped with a resettable circuit breaker on the power input circuit. If the breaker trips, all sections of this product will lose power. Refer to the following instructions for resetting the breaker.

This product is equipped with a resettable circuit breaker. If the breaker trips, all sections of this product will lose power.

1. Disconnect the product from power.
2. Allow the product to cool for 15 minutes.
3. After 15 minutes, try to reset the breaker by pressing the button until it latches in the operation position.
4. Connect the product to power and continue using as recommended.



Disconnect this product from the power outlet before resetting the breaker. If the breaker does not reset (the breaker will not remain in the ON position), contact Chauvet immediately. This indicates a possible internal malfunction.

DMX Linking

You can link the Vesuvio RGBA to a DMX controller using a 3- or 5-pin DMX connection. If using other DMX compatible products with the Vesuvio RGBA, you can control each individually with a single DMX controller.

DMX Personalities

- The Vesuvio RGBA uses a 3- or 5-pin DMX data connection for its 9-channel DMX personality.
- Refer to the [Introduction](#) chapter for a brief description of each DMX personality.
 - Refer to the [Operation](#) chapter to learn how to configure the Vesuvio RGBA to work in these personalities.
 - The [DMX Values](#) section provides you with detailed information regarding the DMX personalities.



If you are not familiar with or need more information about DMX standards or the DMX cables needed to link this product to a DMX controller, download the DMX Primer from the Chauvet website: www.chauvetlighting.com/download/pro.

Mounting Before mounting this product, read and follow the [Safety Notes](#).

Orientation Always mount this product in a safe position and make sure there is adequate room for ventilation, configuration, and maintenance.

Fluid Tank Orientation

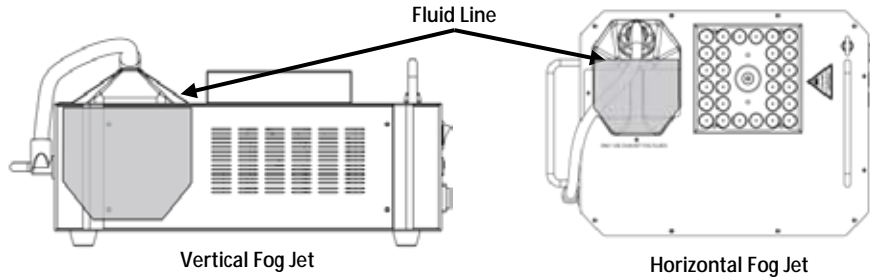

To avoid spillage with any mounting, always position the fluid tank with the tank's cap in the uppermost position above the tank's fluid line.

Rigging

Chauvet recommends using the following general guidelines when mounting this product.

- When selecting an installation location, consider easy access to this product for operation, programming adjustments, and routine maintenance.
- Make sure to mount this product away from any flammable material as indicated in the [Safety Notes](#).
- Never mount in places where rain, high humidity, extreme temperature changes, or restricted ventilation may affect the product.

Procedure

The Vesuvio RGBA comes with rubber feet for floor mounting and 3 - 10 mm threaded holes for overhead mounting. Make sure the clamps are capable of supporting the weight of this product. Use two mounting points per product. In addition, use a safety cable to link the product to the structure.

Mounting Diagram

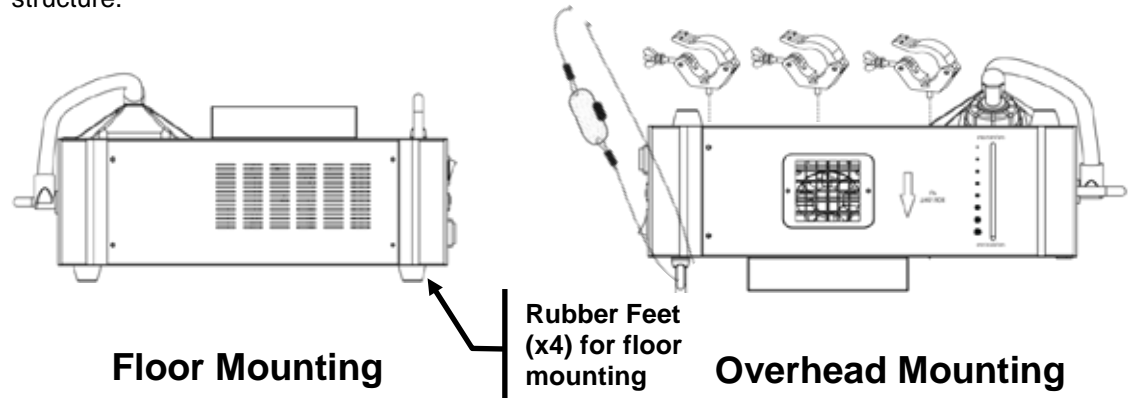

Note: Remove the fluid tank from the holder and set it upright on an adjacent surface when mounting the Vesuvio RGBA in an inverted position to avoid leaking.

Tank Inversion To avoid leaking, invert the fluid tank when mounting this product in an inverted position.

1. Remove the screws and the bottle lock to take out the tank.

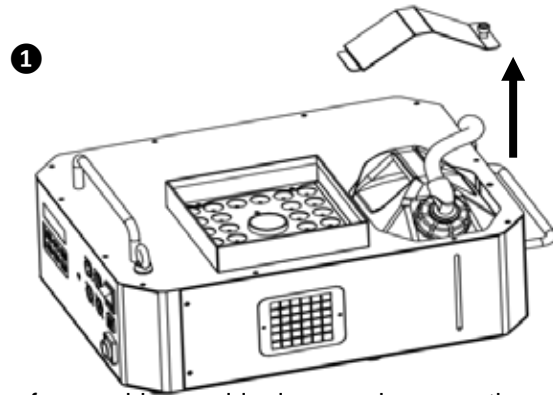

2. Turn the fog machine upside down and remove the screws to take off the removable plate.

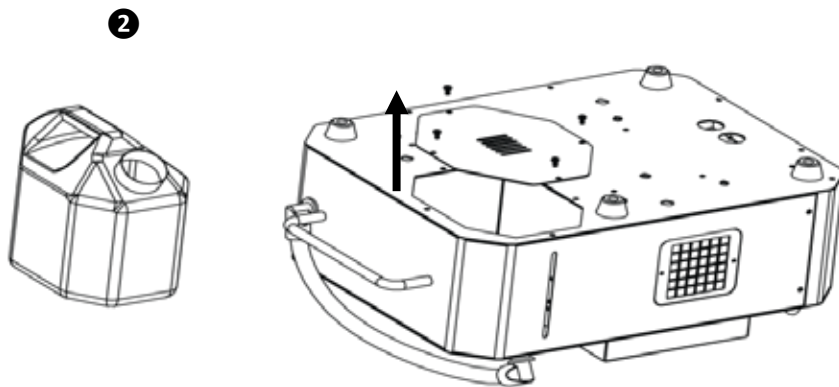

Inverted Mounting

3. Attach the removable plate to the opposite side and secure the tank with the bottle lock.

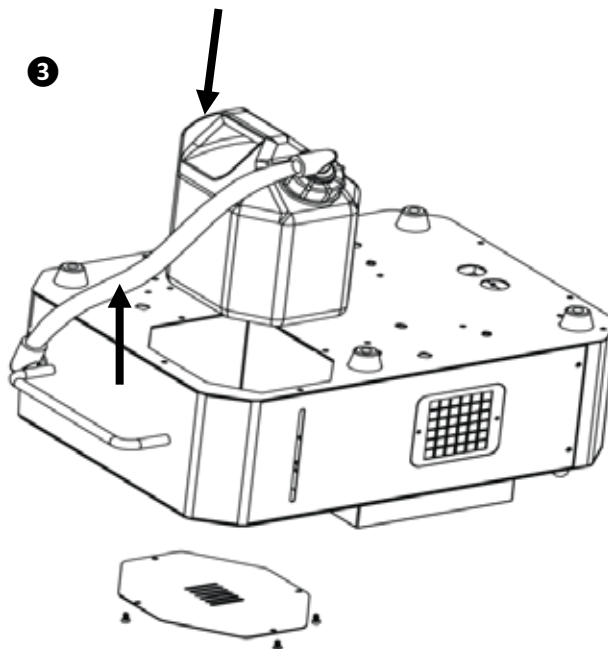

4. OPERATION

Control Panel Description

Button	Function
<FUNCTION>	Enters the programming mode
<VOLUME>	Controls the output as a switch. Press once for full output and press again to turn off
<TIMER>	Starts the timer controlled operation
<MANUAL>	Allows momentary fog output for as long as the button is held down
<UP>	Navigates upward through the menu list or increases the numeric value when in a function
<DOWN>	Navigates downward through the menu list or decreases the numeric value when in a function

Control Options

You can set the Vesuvio RGBA starting address in the **001–512** DMX range. This enables control of up to 56 products in the 9-channel personality.

Programming

Refer to the [Menu Map](#) to understand the menu options. The menu map shows the main level and a variable number of programming levels for each option.

Preparing for Operation

To prepare the Vesuvio RGBA for operation, perform the following steps.

1. Withdraw the fluid tank from its compartment and remove its cap.
2. Verify that the two plastic hoses attached to the cap are in place and in good condition.
3. Pour CHAUVET (QDF) fog fluid into the tank and replace the cap.
4. Return the tank back to its compartment in the Vesuvio RGBA.
5. Make sure the plastic hose entering the Vesuvio RGBA from the fluid tank cap is not bent or kinked.
6. Connect the Vesuvio RGBA to power and **Warming Up** shows on the display during the heating-up process. After approx. 7 minutes, the display changes to **Ready To Vesuvio** when the machine is ready to output.



In any of the operation modes, the display must show Ready To Vesuvio to output haze and light.

Startup

The Vesuvio RGBA has an On/Off switch. Make sure that the switch is in the OFF position before connecting the Vesuvio RGBA to power.

To start up the Vesuvio RGBA, do the following:

1. Prepare for operation, as described in [Preparing for Operation](#).
2. Press <MANUAL> until haze is being output.
 - **Repeat the startup procedure after transporting the Vesuvio RGBA or after refilling with fluid.**
 - **You may hear a loud popping sound during operation. This is normal.**



Menu Map

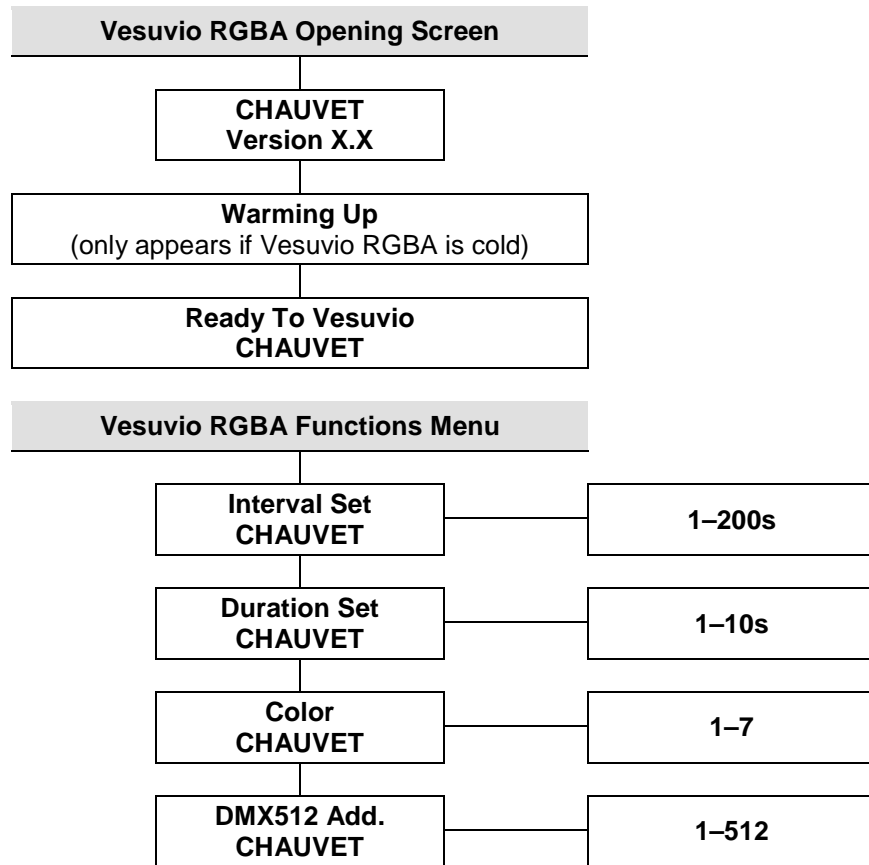

DMX Values

9CH	Channel	Function	Value	Percent/Setting
	1	Fog	000 ∘ 010 011 ∘ 255	No function Fog on
	2	Dimmer	000 ∘ 255	0-100%
	3	Red	000 ∘ 255	0-100%
	4	Green	000 ∘ 255	0-100%
	5	Blue	000 ∘ 255	0-100%
	6	Amber	000 ∘ 255	0-100%
	7	Strobe	000 ∘ 255	0-100%
	8	Auto Color	000 ∘ 010 011 012 013 ∘ 015 16 017 ∘ 019 020 021 ∘ 023 024 025 ∘ 027	No function Amber/Blue Amber Amber/Blue dim to bright Green Green/Blue dim to bright Amber/Green Amber/Green/Blue dim to bright Amber/Green Amber/Green/Blue dim to bright

DMX Values (Cont.)

9CH	Channel	Function	Value	Percent/Setting
			028	Amber/Green
			029	Amber/Green/Blue dim to bright
			032	Green
			033	Green/Blue dim to bright
			036	Amber/Green
			037	Amber/Green/Blue dim to bright
			040	Amber/Green
			041	Green/Blue dim to bright
			044	Amber/Green
			045	Green/Blue dim to bright
			048	Green
			049	Green/Blue dim to bright
			052	Amber/Green
			053	Amber/Green/Blue dim to bright
			056	Amber/Green
			057	Amber/Green/Blue dim to bright
			060	Amber/Green
			061	Amber/Green/Blue dim to bright
			064	Red
			065	Red/Blue dim to bright
			068	Red/Amber
			069	Red/Amber/Blue dim to bright
			072	Red/Amber
			073	Red/Amber/Blue dim to bright
			076	Red/Amber
			077	Red/Amber/Blue dim to bright
			080	Red/Green
			081	Red/Green/Blue dim to bright
			084	Red/Green/Amber
			085	Red/Green/Amber/Blue dim to bright
			088	Red/Green/Amber
			089	Red/Green/Amber/Blue dim to bright
			092	Red/Green/Amber
			093	Red/Green/Amber/Blue dim to bright
			096	Red/Green
			097	Red/Green/Blue dim to bright
			100	Red/Green/Amber
			101	Red/Green/Amber/Blue dim to bright
			104	Red/Green/Amber
			105	Red/Green/Amber/Blue dim to bright
			108	Red/Green/Amber
			109	Red/Green/Amber/Blue
			112	Red/Green
			113	Red/Green/Blue dim to bright
			116	Red/Green/Amber
			117	Red/Green/Amber/Blue dim to bright
			120	Red/Green/Amber
			121	Red/Green/Amber/Blue dim to bright
			124	Red/Green/Amber
			125	Red/Green/Amber/Blue dim to bright
			128	Red
			129	Red/Blue dim to bright
	8	Auto Color		

DMX Values (Cont.)

9CH	Channel	Function	Value	Percent/Setting
			132	Red/Amber
			133 ó 135	Red/Amber/Blue dim to bright
			136	Red/Amber
			137 ó 139	Red/Amber/Blue dim to bright
			140	Red/Amber
			141 ó 143	Red/Amber/Blue dim to bright
			144	Red/Green
			145 ó 147	Red/Amber/Blue dim to bright
			148	Red/Green/Amber
			149 ó 151	Red/Green/Amber/Blue dim to bright
			152	Red/Green/Amber
			153 ó 155	Red/Green/Amber/Blue dim to bright
			156	Red/Green/Amber
			157 ó 159	Red/Green/Amber/Blue dim to bright
			160	Red/Green
			161 ó 163	Red/Green/Blue dim to bright
			164	Red/Green/Amber
			165 ó 167	Red/Green/Amber/Blue dim to bright
			168	Red/Green/Amber
			169 ó 171	Red/Green/Amber/Blue dim to bright
			172	Red/Green/Amber
			173 ó 175	Red/Green/Amber/Blue dim to bright
			176	Red/Green
			177 ó 179	Red/Green/Amber/Blue dim to bright
			180	Red/Green/Amber
			181 ó 183	Red/Green/Amber/Blue dim to bright
			184	Red/Green/Amber
			185 ó 187	Red/Green/Amber/Blue dim to bright
			188	Red/Green/Amber
			189 ó 191	Red/Green/Amber/Blue dim to bright
			192	Red
			193 ó 195	Red/Blue dim to bright
			196	Red/Amber
			197 ó 199	Red/Amber/Blue dim to bright
			200	Red/Amber
			201 ó 203	Red/Amber/Blue dim to bright
			204	Red/Amber
			205 ó 207	Red/Amber/Blue dim to bright
			208	Red/Green
			209 ó 211	Red/Green/Blue dim to bright
			212	Red/Green/Amber
			213 ó 215	Red/Amber/Blue dim to bright
			216	Red/Green/Amber
			217 ó 219	Red/Green/Amber/Blue dim to bright
			220	Red/Green/Amber
			221 ó 223	Red/Green/Amber/Blue dim to bright
			224	Red/Green
			225 ó 227	Red/Green/Blue dim to bright
			228	Red/Green/Amber
			229 ó 231	Red/Green/Amber/Blue dim to bright
			232	Red/Green/Amber
			233 ó 235	Red/Green/Amber/Blue dim to bright
	8	Auto Color		

DMX Values (Cont.)

9CH	Channel	Function	Value	Percent/Setting
	8	Auto Color	236	Red/Green/Amber
			237-239	Red/Green/Amber/Blue dim to bright
			240	Red/Green
			241-243	Red/Green/Blue dim to bright
			244	Red/Green/Amber
			245-247	Red/Green/Amber/Blue dim to bright
			248	Red/Green/Amber
			249-251	Red/Green/Amber/Blue dim to bright
			252	Red/Green/Amber
	253-255	Red/Green/Amber/Blue dim to bright		
	9	Auto Speed	000-255	0-100%

Starting Address The Vesuvio RGBA uses 9 DMX channels in its DMX mode, which defines the highest configurable address to **504**. If unfamiliar with DMX, download the DMX Primer from www.chauvetlighting.com/download/pro.

To select the starting address, do the following:

1. Press **<FUNCTION>** repeatedly until **DMX512 Add.** shows on the display.
2. Use **<UP>** or **<DOWN>** to select the starting address **1–512**.



Make sure that the starting addresses on the various products do not overlap due to the address setting.

Setting the LED Color

To adjust the color of the LED's, do the following:

1. Press **<FUNCTION>** repeatedly until **Color** shows on the display.
2. Use **<UP>** or **<DOWN>** to select the desired color (**1–7**).

Timer Mode

When in Timer mode, the Vesuvio RGBA will produce haze and light in pre-configured time intervals defined by the **Interval Set** and **Duration Set** menu options. See the [Timer Mode Parameters](#) section for details about how to configure these parameters.

To operate in Timer mode, do the following:

1. Press **<TIMER>** and the display will show a countdown of the interval timer.
2. When the counter reaches zero (**0**), the Vesuvio RGBA will start producing haze and light.
3. The haze and light output duration during Timer mode is set by the **Duration Set** menu option.
4. The color of the LEDs is set using the **Color** menu option.
5. This cycle will repeat itself until you press **<TIMER>** again or until the Vesuvio RGBA runs out of fluid.

Manual Mode

In the Manual mode, the Vesuvio RGBA will output haze and light for as long as **<MANUAL>** remains pressed. The output volume will be at 100% full haze and light output.

To operate in Manual mode, do the following:

- Press **<MANUAL>**.

This mode will continue until you release **<MANUAL>** or until the Vesuvio RGBA runs out of fluid.

Timer Mode Parameters

These parameters determine the intervals for the Vesuvio RGBA while in Timer mode.

To configure these parameters do the following.

1. Press **<FUNCTION>** repeatedly until **Interval Set** shows on the display.
2. Use **<UP>** or **<DOWN>** to select the time in seconds (**1–200s**) between haze and light output.
3. Press **<FUNCTION>** repeatedly until **Duration Set** shows on the display.
4. Use **<UP>** or **<DOWN>** to select the time in seconds (**1–10s**) for the duration of the haze and light output.

5. TECHNICAL INFORMATION

Maintenance Do not allow the Vesuvio RGBA to become clogged. Dust build-up reduces light output performance and can cause overheating. This can lead to reduced light source life and increased mechanical wear. After every 40 hours of continuous operation, use CHAUVET Fog Cleaner Quart (FCQ) through the system to prevent the accumulation of particulate matter in the heating element.

The recommended cleaning procedure is as follows.

1. Unplug the product from power.
2. Empty all fluid from the machine.
3. Add cleaning solution to the tank.
4. Connect the product to power and allow it to warm up.
5. Run the product in a well-ventilated area until the tank is empty.
6. Refill with fog fluid to continue using the Vesuvio RGBA. Run the machine briefly to clear any cleaning solution from the pump and heater.
7. Use a vacuum (or dry compressed air) and a soft brush to remove dust collected on the external vents.
8. Clean all external surfaces with a mild solution of non-ammonia glass cleaner or isopropyl alcohol.



FCQ (Fog Cleaner Quart) was specifically developed by Chauvet to clean your Vesuvio RGBA. Make sure you use FCQ regularly to increase the life of your fogger.



Do not spin the fans using compressed air because you could damage the fogger.

Storage

Before storing the Vesuvio RGBA, run FCQ through the system as described in the cleaning procedure above; however, only follow steps 1 through 5. Do not refill the tank with fluid if storing the Vesuvio RGBA. Cleaning the system prior to storage will help prevent any particles from condensing inside the pump or heater while not in use.



Test run your Vesuvio RGBA on a monthly basis to achieve the best performance.

6. TECHNICAL SPECIFICATIONS

Dimensions and Weight	Length	Width	Height	Weight
	13.2 in (336 mm)	19.2 in (488 mm)	9.1 in (231 mm)	30 lb (13.6 kg)
Note: Dimensions in inches rounded to the nearest decimal digit.				
Power	Power Supply Type	Range		Voltage Selection
	Model-specific	120 VAC, 60 Hz		Fixed
	Parameter	120 VAC, 60 Hz		
	Consumption	1,590 W		
	Current	13.25 A		
	Breaker	15 A		
Power I/O	Power I/O	U.S./Canada	Worldwide	
	Power input connector	Neutrik® powerCON® A	Neutrik® powerCON® A	
	Power cord plug	Edison (U.S.)	Local plug	
Light Source	Type	Power	Lifespan	
	LED	2 W	50,000 hours	
	Color	Quantity	Current	
	Red	7	650 mA	
	Green	7	650 mA	
	Blue	7	650 mA	
	Amber	7	650 mA	
Photo Optic	Parameter	Standard Optics		
	Illuminance @ 5 m	720 lux		
Operation/Capacity/Consumption	Heat-up Time	Tank Capacity	Fluid Consumption	
	7 min	0.7 gal (2.5 l)	82 ml/min	
Misc.	Output			
	40,000 cfm			
Thermal	Max. External Temperature	Cooling System		
	104 °F (40 °C)	Fan-cooled		
DMX	I/O Connectors	Connector Type	Channel Range	
	3- and 5-pin XLR	Sockets	9	
Ordering	Product Name	Item Code	UPC Number	
	Vesuvio RGBA	05070860	781462212087	



Returns You must send the product prepaid, in the original box, and with the original packing and accessories. Chauvet will not issue call tags. Call Chauvet and request a Return Merchandise Authorization (RMA) number before shipping the product. Be prepared to provide the model number, serial number, and a brief description of the cause(s) for the return. Clearly label the package with an RMA number. Chauvet will refuse any product returned without an RMA number.



DO NOT write the RMA number directly on the box. Instead, write it on a properly affixed label.

Once you have received the RMA number, include the following information on a piece of paper inside the box:

- Your name
- Your address
- Your phone number
- The RMA number
- A brief description of the problem(s)

Be sure to pack the product properly. Any shipping damage resulting from inadequate packaging will be the customer's responsibility. FedEx packing or double-boxing is recommended.



Chauvet reserves the right to use its own discretion to repair or replace returned product(s).

CONTACT Us

USA WORLD HEADQUARTERS

General Information – Chauvet

Address: 5200 NW 108th Avenue
Sunrise, FL 33351

Voice: (954) 577-4455

Fax: (954) 929-5560

Toll free: (800) 762-1084

Technical Support

Voice: (844) 393-7575

Fax: (954) 756-8015

Email: chauvetcs@chauvetlighting.com

World Wide Web www.chauvetlighting.com

EUROPE

General Information - Chauvet Europe BVBA

Address: Stokstraat 18
9770 Kruishoutem
Belgium

Voice: +32 9 388 93 97

Technical Support

Email: Eutech@chauvetlighting.eu

World Wide Web www.chauvetlighting.eu

General Information - Chauvet Europe Ltd.

Address: Unit 1C
Brookhill Road Industrial Estate
Pinxton, Nottingham, UK
NG16 6NT

Voice: +44 (0)1773 511115

Fax: +44 (0)1773 511110

Technical Support

Email: uktech@chauvetlighting.com

World Wide Web www.chauvetlighting.co.uk

MEXICO

General Information - Chauvet Mexico

Address: Av. De las partidas 34 – 3B
(Entrance by Calle 2)
Zona Industrial Lerma
Lerma, Edo. de Mexico C.P. 52000

Voice: +52 (728) 690-2010

Technical Support

Email: servicio@chauvet.com.mx

World Wide Web www.chauvet.com.mx

Outside the U.S., United Kingdom, Ireland, Mexico, or Benelux contact the dealer of record. Follow their instructions to request support or to return a product. Visit our website for contact details.