

Ovation™ C-640FC

User Manual

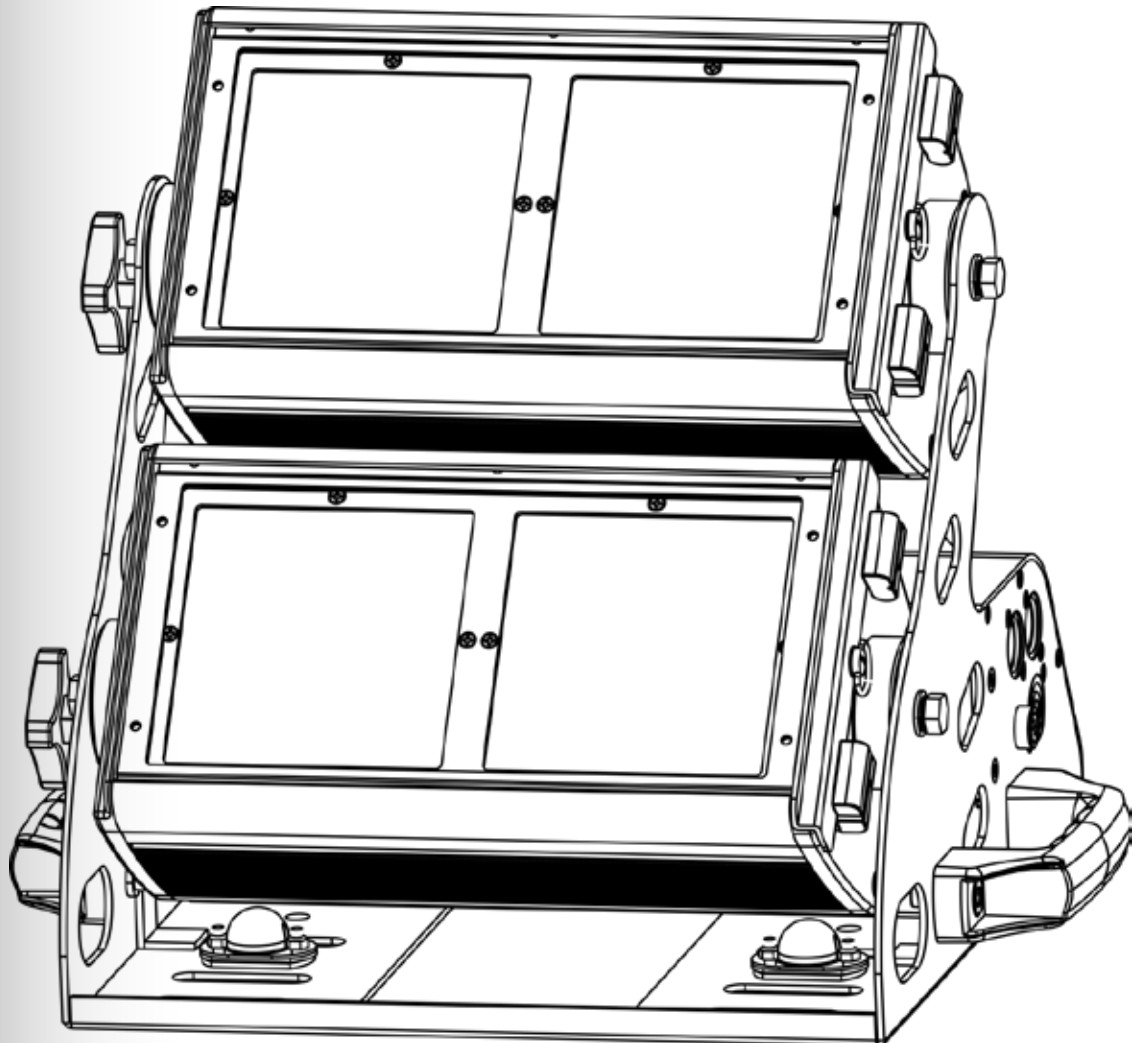

CHAUVET
PROFESSIONAL®

Edition Notes The OVATION C-640FC User Manual Rev. 6 covers the description, safety precautions, installation, programming, operation, and maintenance of the OVATION C-640FC. Chauvet released this edition of the OVATION C-640FC User Manual in February 2017.

Trademarks CHAUVET is a registered trademark of CHAUVET & Sons LLC. (d/b/a CHAUVET or Chauvet). The CHAUVET logo in its entirety including the CHAUVET name and the dotted triangle, and all other trademarks in this manual pertaining to services, products, or marketing statements are owned or licensed by Chauvet. Any other product names, logos, brands, company names, and other trademarks featured or referred to within this document are the property of their respective trademark holders.

Copyright Notice Chauvet owns the content of this User Manual in its entirety, including but not limited to pictures, logos, trademarks, and resources.

© **Copyright 2017 Chauvet. All rights reserved.**

Electronically published by Chauvet in the United States of America.

Manual Use Chauvet authorizes its customers to download and print this manual for professional information purposes only. Chauvet expressly prohibits the usage, copy, storage, distribution, modification, or printing of this manual or its content for any other purpose without written consent from Chauvet.

Document Printing For better results, print this document in color, on letter size paper (8.5 x 11 in), double-sided. If using A4 paper (210 x 297 mm), configure your printer to scale the content accordingly.

Intended Audience Any person in charge of installing, operating, and/or maintaining this product should completely read through the guide that shipped with the product, as well as this manual, before installing, operating, or maintaining this product.

Disclaimer Chauvet believes that the information contained in this manual is accurate in all respects. However, Chauvet assumes no responsibility for any errors or omissions in this document. Chauvet reserves the right to revise and make changes to the content of this document without obligation that Chauvet notify any person or company of such revision or changes. This does not in any way constitute a commitment by Chauvet to make such changes. Chauvet may issue a revision of this manual or a new edition to incorporate such changes.

Document Revision The OVATION C-640FC User Manual Rev. 6 supersedes all previous versions of this manual. Discard any older versions of this manual and replace with this version.

Table of Contents

1. Before You Begin	1
What is Included	1
Claims	1
Manual Conventions	1
Symbols	1
Product at a Glance	1
Safety Notes	2
Personal Safety	2
Mounting and Rigging	2
Power and Wiring	2
Operation	2
Expected LED Lifespan	2
2. Introduction	3
Description	3
Features	3
Overview	4
Dimensions	5
3. Setup	6
AC Power	6
AC Plug	6
Fuse Replacement	6
Power Linking	7
DMX Linking	7
DMX Modes	7
Master/Slave Connectivity	7
Mounting	8
Orientation	8
Rigging	8
4. Operation	9
Control Panel Description	9
Control Options	9
Programming	9
Menu Map	10
DMX Values	13
TOUR	13
TR16	15
ARC.1	17
AR1.D	17
ARC.2	17
ARC.3	17
AR3.D	17
AR3.S	18
HSV	18
PX16	19
PIX1	20
PIX3	20
OVATION C-640FC Sections for DMX Pixel Control	20
Virtual Color Wheel	21
Color Chart	21
DMX Personality	22
DMX Control	22
Loss of Signal Setting	22
Dimming Profiles	23

Control Panel Lock.....	23
Passcode	23
Menu Access Lock.....	23
Setting Color Balance	23
Strobe Options for TOUR and TR16	23
Color Macros and White Settings.....	24
White Calibration.....	24
Resetting the CAL Settings	24
Configuration (Standalone).....	25
Static Mode	25
Auto and Customizable Programs.....	25
Selecting from the Virtual Color Wheel	25
Edit Custom Programs	26
Reset.....	26
Master/Slave Mode	27
Program Upload.....	27
5. Technical Information	28
Product Maintenance.....	28
Technical Specifications	29
Returns	30
Contact Us.....	30

1. Before You Begin

What is Included

- OVATION C-640FC
- Neutrik powerCON power cord
- 2 Omega Brackets with Mounting Hardware
- 2 Gel Frames 5.32 x 9.65 in (135 x 245 mm)
- Warranty Card
- Quick Reference Guide

Claims

Carefully unpack the product immediately and check the box to make sure all the parts are in the package and are in good condition.



If the box or the contents (the product and included accessories) appear damaged from shipping or show signs of mishandling, notify the carrier immediately, not Chauvet. Failure to report damage to the carrier immediately may invalidate your claim. In addition, keep the box and contents for inspection.

For other issues, such as missing components or parts, damage not related to shipping, or concealed damage, file a claim with Chauvet within 7 days of delivery.

Manual Conventions

Convention	Meaning
1–512	A range of values in the text
50/60	A set of mutually exclusive values in the text
<SET>	A button on the product’s control panel
Settings	A product function or a menu option
MENU>Settings	A sequence of menu options
1–10	A range of menu values from which to choose in a menu
Yes/No	A set of two mutually exclusive menu options in a menu
ON	A unique value to be entered or selected in a menu

Symbols

Symbols	Meaning
	Critical installation, configuration, or operation information. Failure to comply with this information may cause the product not to work, damage third-party equipment, or cause harm to the operator.
	Important installation or configuration information. Failure to comply with this information may keep the product from working.
	Useful information.



The term “DMX” used throughout this manual refers to the USITT DMX512-A digital data transmission protocol.

Product at a Glance

Use on Dimmer	X	Auto Programs	P
Outdoor Use	X	Auto-Ranging Power Supply	P
Sound-Active	X	Replaceable Fuse	P
DMX	P	User-Serviceable	X
Master/Slave	P	Duty Cycle	X

Safety Notes

Read all the following Safety Notes before working with this product. These notes include important information about the installation, usage, and maintenance of this product.



This product contains no user-serviceable parts. Any reference to servicing in this User Manual will only apply to properly trained Chauvet certified technicians. Do not open the housing or attempt any repairs.



All applicable local codes and regulations apply to proper installation of this product.

Personal Safety

- Avoid direct eye exposure to the light source while the product is on.
- Always disconnect this product from its power source before servicing.
- Always connect this product to a grounded circuit to avoid the risk of electrocution.
- Do not touch this product's housing during operation because it may be very hot.
- This product is for indoor use only! (IP20) To prevent risk of fire or shock, do not expose this product to rain or moisture.
- CAUTION: When transferring product from extreme temperature environments, (e.g. cold truck to warm humid ballroom) condensation may form on the internal electronics of the product. To avoid causing a failure, allow product to fully acclimate to the surrounding environment before connecting it to power.
- Mount this product in a location with adequate ventilation, at least 20 in (50 cm) from adjacent surfaces.
- Make sure there are no flammable materials close to this product while it is operating.
- When hanging this product, always secure to a fastening device using a safety cable.

Mounting and Rigging

Power and Wiring

- Always make sure you are connecting this product to the proper voltage in accordance with the specifications in this manual or on the product's specification label.
- Never connect this product to a dimmer pack or rheostat.

Operation

- Never disconnect this product by pulling or tugging on the power cable.
- Do not operate this product if you see damage on the housing, lenses, or cables. Have the damaged parts replaced by an authorized technician at once.
- To eliminate unnecessary wear and improve its lifespan, during periods of non-use completely disconnect the product from power via breaker or by unplugging it.
- Do not cover the ventilation slots when operating to avoid internal overheating.
- The maximum ambient temperature is 113 °F (45 °C). Do not operate this product at a higher temperature.
- In case of a serious operating problem, stop using this product immediately!



Expected LED Lifespan

In the unlikely event that your Chauvet product may require service, contact Chauvet Technical Support.

LEDs gradually decline in brightness over time, mostly because of heat. Packaged in clusters, LEDs exhibit higher operating temperatures than in ideal, single-LED conditions. For this reason, using clustered LEDs at their fullest intensity significantly reduces the LEDs' lifespan. Under normal conditions, this lifespan can be 40,000 to 50,000 hours. If extending this lifespan is vital, lower the operating temperature by improving the ventilation around the product and reducing the ambient temperature to an optimal operating range. In addition, limiting the overall projection intensity may also help to extend the LEDs' lifespan.

2. Introduction

Description

The OVATION C-640FC is a compact cyclorama wash light capable of displaying a full spectrum of hues with RGBWA LEDs. It is theater-ready with 16-bit dimming of the individual colors and the master dimmer. Control options include 12 DMX modes and static color mixing without DMX control. Two individually adjustable heads offer great coverage.

Features

- Compact cyclorama RGBWA LED wash
- Operating modes:
 - 3-channel (HSV): color hue, saturation, and value control
 - 4-channel (ARC.1): RGB and virtual color wheel control
 - 5-channel (AR1.D): RGB, virtual color wheel, and dimmer control
 - 5-channel (ARC.2): RGBW and virtual color wheel control
 - 6-channel (ARC.3): RGBWA and virtual color wheel control
 - 7-channel (AR3.D): RGBWA, virtual color wheel, and dimmer control
 - 8-channel (PIX1): RGB and virtual color wheel control (both with pixel 1 and pixel 2 control)
 - 8-channel (AR3.S): RGBWA, virtual color wheel, dimmer, and strobe control
 - 12-channel (TOUR): RGBWA, virtual color wheel, dimmer, strobe (classic and special), programs (auto and custom), auto speed, dimmer speed, color macro, and white balance control
 - 12-channel (PIX3): RGBWA and virtual color wheel control (both with pixel 1 and pixel 2 control)
 - 24-channel (PX16): RGBWA, fine RGBWA, virtual color wheel control (both with pixel 1 and pixel 2 control), dimmer, fine dimmer
 - 18-channel (TR16): RGBWA, fine RGBWA, virtual color wheel, dimmer, fine dimmer, strobe (classic and special), color macro, and white balance control
- Static color mixing without DMX control
- 16-bit dimming of master dimmer and individual colors
- Two individually adjustable heads
- 3- and 5-pin XLR data input and output connectors

Overview

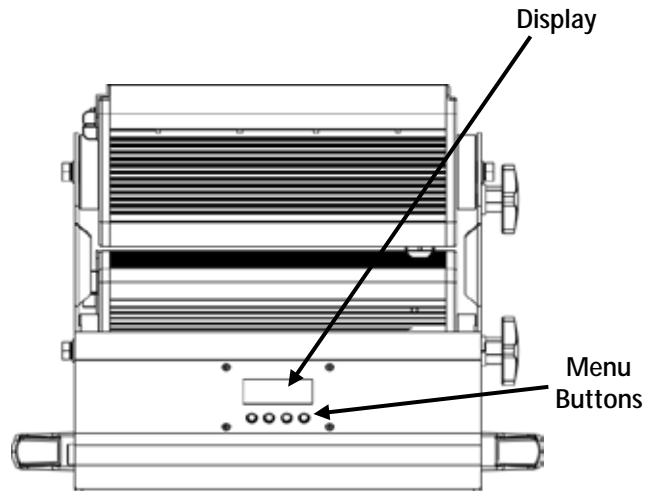

Rear View

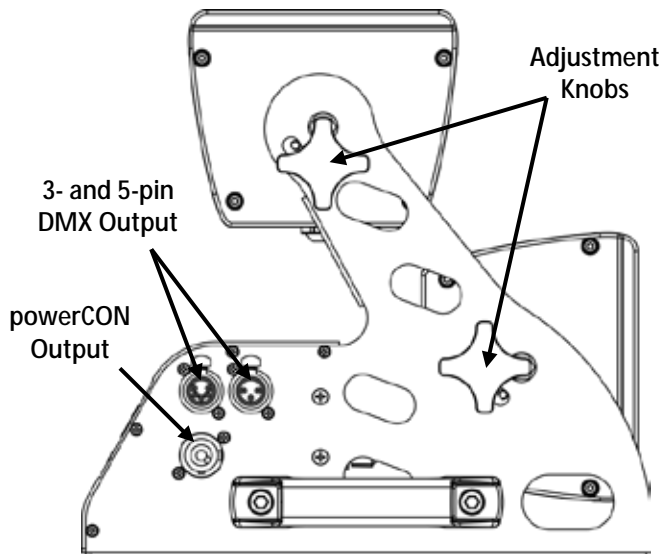

Left View

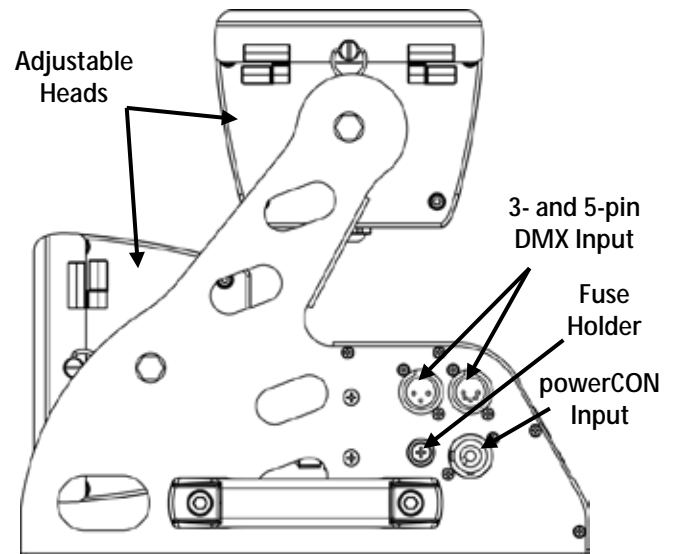

Right View

Dimensions

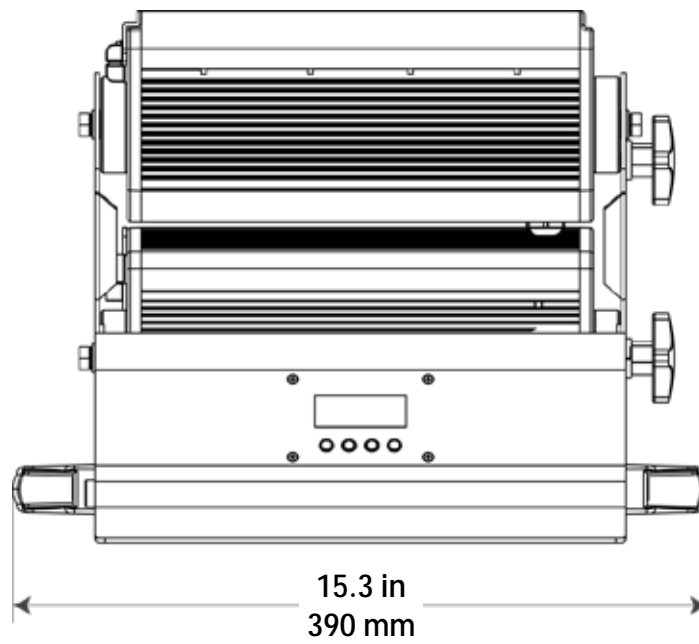
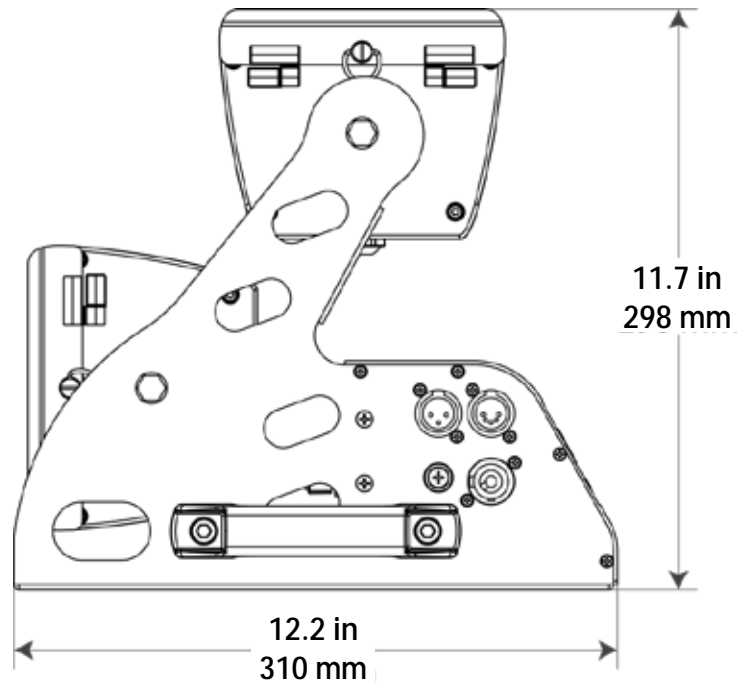

3. Setup

AC Power

Each OVATION C-640FC has an auto-ranging power supply that works with an input voltage range of 100~240 VAC, 50/60 Hz. To determine the power requirements for each OVATION C-640FC, refer to the label affixed to the product. You can also refer to the [Technical Specifications](#) chart in this manual.

The listed current rating indicates the maximum current draw during normal operation. For more information, you may download Sizing Circuit Breakers from the Chauvet website www.chauvetprofessional.com.



- **Always connect this product to a protected circuit with an appropriate electrical ground to avoid the risk of electrocution or fire.**
- **To eliminate unnecessary wear and improve its lifespan, during periods of non-use completely disconnect the product from power via breaker or by unplugging it.**



Never connect this product to a rheostat (variable resistor) or dimmer circuit, even if the rheostat or dimmer channel serves only as a 0 to 100% switch.

AC Plug

The OVATION C-640FC comes with a power input cord terminated with a Neutrik powerCON A connector on one end and an Edison plug on the other end (U.S. market). If the power input cord that came with your product has no plug, or if you need to change the Edison plug, use the table below to wire the new plug to the power input cord.

Connection	Wire (U.S.)	Wire (Europe)	Screw Color
AC Live	Black	Brown	Yellow or Brass
AC Neutral	White	Blue	Silver
AC Ground	Green/Yellow	Green/Yellow	Green

Fuse Replacement



Make sure to disconnect the product's power cord before replacing a blown fuse.

1. Disconnect this product from power.
2. Using a Phillips #2 head screwdriver, unscrew the fuse holder cap from the housing.
3. Remove the blown fuse and replace with another fuse of the same type and rating (T 5 A, 250 V).
4. Screw the fuse holder cap back in place and reconnect power.



Always replace the blown fuse with another of the same type and rating.

Power Linking The OVATION C-640FC supports power linking. You can power link up to 9 units on 120 V; up to 16 units on 208 V; or up to 18 units on 230 V.

This product comes with a Neutrik powerCON input power cord. This product does not come with a power linking cable; however, a power linking cable is available as an option.

DMX Linking You can link the OVATION C-640FC to a DMX controller using a standard DMX serial connection. If using other DMX-compatible products with the OVATION C-640FC, you can control each individually with a single DMX controller.

DMX Modes The OVATION C-640FC uses the standard DMX data connection for its **TOUR**, **TR16**, **ARC.1**, **AR1.D**, **ARC.2**, **ARC.3**, **AR3.D**, **AR3.S**, **HSV**, **PIX1**, **PIX3**, and **PX16** DMX modes.

- Refer to the [Introduction](#) chapter for a brief description of these modes.
- Refer to the [Operation](#) chapter to learn how to configure the OVATION C-640FC to work in these modes.
- The [DMX Values](#) section provides you with detailed information regarding the DMX modes.

Master/Slave Connectivity The Master/Slave mode allows a single OVATION C-640FC (the “master”) to control the actions of one or more OVATION C-640FC units (the “slaves”) without the need of a DMX controller to control the slaves. Once set and connected, the slaves will operate in unison with the master. For instructions on connecting and configuring this product, see [Master/Slave Mode](#).



DO NOT connect a DMX controller to products operating in Slave mode. The DMX controller signals may interfere with the signals from the master product.



The [Operation](#) section of this manual provides detailed instructions on how to configure the master and slave products.



If you are not familiar with or need more information about DMX standards, master/slave connectivity, or the DMX cables needed to link this product to a DMX controller, download the *DMX Primer* from the Chauvet website: www.chauvetprofessional.com.

- Mounting** Before mounting this product, read and follow the [Safety Notes](#). For our CHAUVET Professional line of mounting clamps, go to <http://trusst.com/products/>.
- Orientation** Always mount this product in a safe position. The OVATION C-640FC may be mounted in any position; however, make sure there is adequate room for ventilation, configuration, and maintenance.
- Rigging** Chauvet recommends using the following general guidelines when mounting this product.
- When selecting an installation location, consider easy access to this product for operation, programming adjustments, and routine maintenance.
 - Make sure to mount this product away from any flammable material as indicated in the [Safety Notes](#).
 - Never mount in places where rain, high humidity, extreme temperature changes, or restricted ventilation may affect the product.
 - If hanging this product, make sure that the mounting location can support the product's weight. See the [Technical Specifications](#) for the weight-bearing requirements of this product.
 - When hanging this product, always secure to a fastening device using a safety cable.
- Procedure** The OVATION C-640FC comes with two omega brackets to which you can attach mounting clamps. You must supply your own clamps and make sure that they are capable of supporting the weight of this product. You will have to use two mounting points per product.

Mounting Diagram

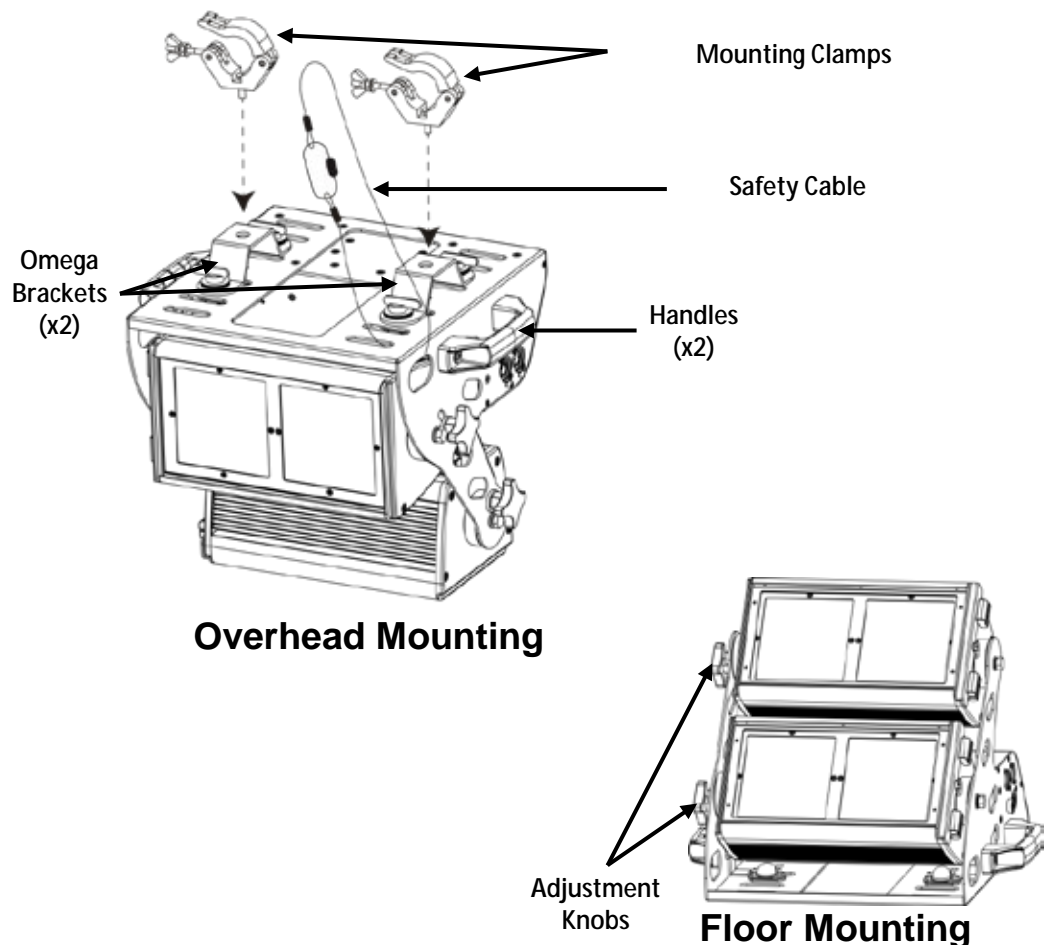

4. Operation

Control Panel Description

Button	Function
<MENU>	Exits from the current menu or function
<ENTER>	Activates the currently displayed menu option or sets the selected value in the current function
<UP>	Scrolls up the list of menu options or increases the numeric value when in a function
<DOWN>	Scrolls down the list of menu options or decreases the numeric value when in a function

Control Options

You can set the starting address of the OVATION C-640FC in the **001–512** DMX range. This enables control of up to 21 products in the 18-channel **PX16** personality.

Programming

Refer to the [Menu Map](#) for a description of your programming options. The menu map shows the main level and a variable number of programming levels for each option.

- Press <MENU> repeatedly to go to the desired main level. Press <ENTER> to select the main level and go to the first programming level for that option.
- Press <UP> or <DOWN> to scroll through the options or values within the current programming level. When the desired option shows on the display, press <ENTER> to select the option. If there are deeper programming levels, those options will show on the display.
- Press <MENU> repeatedly to exit to the previous level.

Menu Map

Main Level	Programming Levels		Description
STAT	RED	X.000–X.255	Combines red, green, blue, white, and amber to make a custom color (0–100%)
	GREN		
	BLUE		
	WHIT		
	AMBR		
	STRB	S.000–S.020	Selects the strobe frequency (0–20 Hz)
VCW	C90Y		Virtual Color Wheel simulates the output of each gel color from . Refer to the Color Chart section for specific values.
	R11		
	R312		
	R03		
	R18		
	R20		
	R21		
	R26		
	R27		
	R33		
	R337		
	R38		
	R41		
	R42		
	R44		
	R349		
	R54		
	R64		
	R364		
	R65		
	R80		
	R81		
	R82		
	R382		
	R83		
	R383		
R91			
R92			
R93			
R393			
R90			

Menu Map (cont.)

Main Level	Programming Levels		Description		
AUTO	AT.01–AT.10	P.000–P.255	Selects auto programs and auto program speed		
	PR.01–PR.10		Selects customizable programs		
RUN	DMX		Receives DMX signals from the DMX controller		
	SLAV		Receives DMX signals from the master		
ADDR	D.001–D.512		Sets the DMX starting address		
PERS	TOUR		12-channel; RGBWA, VCW, dimmer, strobe, color macro, auto/custom, dimmer speed, auto speed		
	TR16		18-channel: 16-bit- RGBWA, VCW, dimmer, strobe, color macro, auto/custom, dimmer speed, auto speed		
	ARC.1		4-channel: RGB control, VCW		
	AR1.D		5-channel: RGB, dimmer, VCW		
	ARC.2		5-channel: RGBW control, VCW		
	ARC.3		6-channel: RGBWA control, VCW		
	AR3.D		7-channel: RGBWA, dimmer, VCW		
	AR3.S		8-channel: RGBWA, dimmer, strobe, VCW		
	HSV		3-channel: HSV control		
	PIX1		8-channel: RGB pixel control, VCW		
	PIX3		12-channel: RGBWA pixel control, VCW		
EDIT	PR.01–PR.10	SC.01–SC.30	RED	X.000–X.255	Combines red, green, blue, white and amber to generate a custom color (0–100%)
			GREN		
			BLUE		
			WHIT		
			AMBE		
	STRB	S.000–S.020	Selects strobe frequency (0–20 Hz)		
	TIME	T.000–T.255	Defines the step duration (slow to fast)		
	FADE	F.000–F.255	Defines the fade duration (slow to fast)		

Menu Map (cont.)

Main Level	Programming Levels				Description	
SET	KEY	ON			Sets to key lock (Passcode mode)	
		OFF				
	UPLD	**** (Enter Passcode)	SEND	OK	Uploads custom programs to other OVATION C-640FCs	
	REST	**** (Enter Passcode)	SEND	OK	Resets the fixture to factory defaults	
	COLR	OFF			RGB set to 255 , max. output	
		RGBW			RGB set to 255 , balanced white	
		UC			Universal color balance	
	DIMX	OFF			Selects dimming profiles from fast (DIM1) to slow (DIM4) or OFF	
		DIM1				
		DIM2				
		DIM3				
		DIM4				
	DERR	BLAK			Blacks out fixture upon loss of DMX signals	
		SAVE			Continues with last command upon loss of DMX signals	
SLCK	OFF			Sets menu-level access lock		
	ON					
STRB	SPEC			Selects strobe behavior displayed in TOUR and TR16 personalities		
	CLAS					
MCON	SELF			No DMX signals are sent through DMX output		
	MAST			Sends DMX signals to OVATION C-640FC slaves		
CAL	**** (Enter Passcode)	CAL1	WH.01– WH.11	RED	X.000– X.255	Modifies the color macros used in the TOUR and TR16 personalities
				GREN		
				BLUE		
				WHIT		
AMBE						
CAL2	RED			Defines the color temperature used when COLR is set to RGBW		
	GREN					
	BLUE					
CALR		**** (Enter Passcode)			Defaults CAL to factory settings	

DMX Values

TOUR	Channel	Function	Value	Percent/Setting
	1	Dimmer	000 ó 255	0–100%
	2	Red	000 ó 255	0–100% (Step Duration if Custom 1–10 active)
	3	Green	000 ó 255	0–100% (Fade Duration if Custom 1–10 active)
	4	Blue	000 ó 255	0–100%
	5	White	000 ó 255	0–100%
	6	Amber	000 ó 255	0–100%
	7	Virtual Color Wheel	000 ó 255	Refer to the Color Chart section for specific values
	8	Color Macro + White Balance	000 ó 010	No function
			011 ó 030	R: 100% G: 0-100% B: 0
			031 ó 050	R: 100%-0 G: 100% B: 0
			051 ó 070	R: 0 G: 100% B: 0-100%
			071 ó 090	R: 0 G: 100%-0 B: 100%
			091 ó 110	R: 0-100% G: 0 B: 100%
			111 ó 130	R: 100% G: 0 B: 100%-0
			131 ó 150	R: 100% G: 0-100% B: 0-100%
			151 ó 170	R: 100%-0 G: 100%-0 B: 100%
			171 ó 200	RGBWA: 100%
			201 ó 205	White 1
			206 ó 210	White 2
			211 ó 215	White 3
			216 ó 220	White 4
			221 ó 225	White 5
			226 ó 230	White 6
	231 ó 235	White 7		
	236 ó 240	White 8		
	241 ó 245	White 9		
	246 ó 250	White 10		
	251 ó 255	White 11		
	Special Strobe		000 ó 009	No function
			010 ó 099	Slow to fast
			100 ó 109	No function
			110 ó 179	Lighting effect, slow to fast
			180 ó 189	No function
			190 ó 255	Random
	9*	Classic Strobe	000 ó 009	No function
			010 ó 019	1 Hz
			020 ó 029	2 Hz
			030 ó 039	3 Hz
			040 ó 049	4 Hz
			050 ó 059	5 Hz
			060 ó 069	6 Hz
			070 ó 079	7 Hz
			080 ó 089	8 Hz
			090 ó 099	9 Hz
			100 ó 109	10 Hz
			110 ó 119	11 Hz
			120 ó 129	12 Hz
			130 ó 139	13 Hz
			140 ó 149	14 Hz
	150 ó 159	15 Hz		
	160 ó 169	16 Hz		
	170 ó 179	17 Hz		
	180 ó 189	18 Hz		
	190 ó 199	19 Hz		
	200 ó 255	20 Hz		

*Select strobe function in the main menu under **SET > STRB**, then select **SPEC** or **CLAS**

DMX Values (cont.)

TOUR (cont.)	Channel	Function	Value	Percent/Setting
	10	Programs	000 ó 040	No function
			041 ó 050	Auto 1
			051 ó 060	Auto 2
			061 ó 070	Auto 3
			071 ó 080	Auto 4
			081 ó 090	Auto 5
			091 ó 100	Auto 6
			101 ó 110	Auto 7
			111 ó 120	Auto 8
			121 ó 130	Auto 9
			131 ó 140	Auto 10
			141 ó 150	Custom 1
			151 ó 160	Custom 2
			161 ó 170	Custom 3
			171 ó 180	Custom 4
			181 ó 190	Custom 5
	191 ó 200	Custom 6		
	201 ó 210	Custom 7		
	211 ó 220	Custom 8		
	221 ó 230	Custom 9		
	231 ó 255	Custom 10		
	11	Auto Speed	000 ó 255	0–100%
	12	Dimmer Speed	000 ó 009	Preset dimming profile from display menu
			010 ó 029	Linear dimmer
			030 ó 069	Nonlinear dimming profile 1 (fastest)
			070 ó 129	Nonlinear dimming profile 2
			130 ó 189	Nonlinear dimming profile 3
			190 ó 255	Nonlinear dimming profile 4 (slowest)

DMX Values (cont.)

TR16	Channel	Function	Value	Percent/Setting
	1	Dimmer	000 ó 255	0–100%
	2	Fine Dimmer	000 ó 255	0–100%
	3	Red	000 ó 255	0–100%
	4	Fine Red	000 ó 255	0–100%
	5	Green	000 ó 255	0–100%
	6	Fine Green	000 ó 255	0–100%
	7	Blue	000 ó 255	0–100%
	8	Fine Blue	000 ó 255	0–100%
	9	White	000 ó 255	0–100%
	10	Fine White	000 ó 255	0–100%
	11	Amber	000 ó 255	0–100%
	12	Fine Amber	000 ó 255	0–100%
	13	Virtual Color Wheel	000 ó 255	Refer to Color Chart section for specific values
	14	Color Macro + White Balance	000 ó 010	No function
			011 ó 030	R: 100% G: 0-100% B: 0
			031 ó 050	R: 100%-0 G: 100% B: 0
			051 ó 070	R: 0 G: 100% B: 0-100%
			071 ó 090	R: 0 G: 100%-0 B: 100%
			091 ó 110	R: 0-100% G: 0 B: 100%
			111 ó 130	R: 100% G: 0 B: 100%-0
			131 ó 150	R: 100% G: 0-100% B: 0-100%
			151 ó 170	R: 100%-0 G: 100%-0 B: 100%
			171 ó 200	RGBWA: 100%
			201 ó 205	White 1
			206 ó 210	White 2
			211 ó 215	White 3
			216 ó 220	White 4
			221 ó 225	White 5
			226 ó 230	White 6
			231 ó 235	White 7
	236 ó 240	White 8		
	241 ó 245	White 9		
	246 ó 250	White 10		
	251 ó 255	White 11		

DMX Values (cont.)

TR16 (cont.)	Channel	Function	Value	Percent/Setting
15*	Special Strobe		000 ó 009	No function
			010 ó 099	Slow to fast
			100 ó 109	No function
			110 ó 179	Lighting effect, slow to fast
			180 ó 189	No function
			190 ó 255	Random
	Classic Strobe		000 ó 009	No function
			010 ó 019	1 Hz
			020 ó 029	2 Hz
			030 ó 039	3 Hz
			040 ó 049	4 Hz
			050 ó 059	5 Hz
			060 ó 069	6 Hz
			070 ó 079	7 Hz
			080 ó 089	8 Hz
			090 ó 099	9 Hz
			100 ó 109	10 Hz
			110 ó 119	11 Hz
			120 ó 129	12 Hz
			130 ó 139	13 Hz
		140 ó 149	14 Hz	
	150 ó 159	15 Hz		
	160 ó 169	16 Hz		
	170 ó 179	17 Hz		
	180 ó 189	18 Hz		
	190 ó 199	19 Hz		
	200 ó 255	20 Hz		
16	Programs		000 ó 040	No function
			041 ó 050	Auto 1
			051 ó 060	Auto 2
			061 ó 070	Auto 3
			071 ó 080	Auto 4
			081 ó 090	Auto 5
			091 ó 100	Auto 6
			101 ó 110	Auto 7
			111 ó 120	Auto 8
			121 ó 130	Auto 9
			131 ó 140	Auto 10
			141 ó 150	Custom 1
			151 ó 160	Custom 2
			161 ó 170	Custom 3
			171 ó 180	Custom 4
	181 ó 190	Custom 5		
	191 ó 200	Custom 6		
	201 ó 210	Custom 7		
	211 ó 220	Custom 8		
	221 ó 230	Custom 9		
	231 ó 255	Custom 10		
17	Auto Speed		000 ó 255	0–100%
18	Dimmer Speed		000 ó 009	Preset dimming profile from display menu
			010 ó 029	Linear dimmer
			030 ó 069	Nonlinear dimming profile 1 (fastest)
			070 ó 129	Nonlinear dimming profile 2
			130 ó 189	Nonlinear dimming profile 3
		190 ó 255	Nonlinear dimming profile 4 (slowest)	

*Select strobe function in the main menu under **SET > STRB**, then select **SPEC** or **CLAS**

DMX Values (cont.)

ARC.1	Channel	Function	Value	Percent/Setting
	1	Red	000 ó 255	0–100%
	2	Green	000 ó 255	0–100%
	3	Blue	000 ó 255	0–100%
	4	Virtual Color Wheel	000 ó 255	Refer to Color Chart section for specific values

AR1.D	Channel	Function	Value	Percent/Setting
	1	Dimmer	000 ó 255	0–100%
	2	Red	000 ó 255	0–100%
	3	Green	000 ó 255	0–100%
	4	Blue	000 ó 255	0–100%
	5	Virtual Color Wheel	000 ó 255	Refer to Color Chart section for specific values

ARC.2	Channel	Function	Value	Percent/Setting
	1	Red	000 ó 255	0–100%
	2	Green	000 ó 255	0–100%
	3	Blue	000 ó 255	0–100%
	4	White	000 ó 255	0–100%
	5	Virtual Color Wheel	000 ó 255	Refer to Color Chart section for specific values

ARC.3	Channel	Function	Value	Percent/Setting
	1	Red	000 ó 255	0–100%
	2	Green	000 ó 255	0–100%
	3	Blue	000 ó 255	0–100%
	4	White	000 ó 255	0–100%
	5	Amber	000 ó 255	0–100%
	6	Virtual Color Wheel	000 ó 255	Refer to Color Chart section for specific values

AR3.D	Channel	Function	Value	Percent/Setting
	1	Dimmer	000 ó 255	0–100%
	2	Red	000 ó 255	0–100%
	3	Green	000 ó 255	0–100%
	4	Blue	000 ó 255	0–100%
	5	White	000 ó 255	0–100%
	6	Amber	000 ó 255	0–100%
	7	Virtual Color Wheel	000 ó 255	Refer to Color Chart section for specific values

DMX Values (cont.)

AR3.S	Channel	Function	Value	Percent/Setting
	1	Dimmer	000 ó 255	0–100%
	2	Red	000 ó 255	0–100%
	3	Green	000 ó 255	0–100%
	4	Blue	000 ó 255	0–100%
	5	White	000 ó 255	0–100%
	6	Amber	000 ó 255	0–100%
	7	Virtual Color Wheel	000 ó 255	Refer to Color Chart section for specific values
	8	Classic Strobe	000 ó 009	No function
			010 ó 019	1 Hz
			020 ó 029	2 Hz
			030 ó 039	3 Hz
			040 ó 049	4 Hz
			050 ó 059	5 Hz
			060 ó 069	6 Hz
			070 ó 079	7 Hz
			080 ó 089	8 Hz
			090 ó 099	9 Hz
			100 ó 109	10 Hz
			110 ó 119	11 Hz
			120 ó 129	12 Hz
			130 ó 139	13 Hz
			140 ó 149	14 Hz
			150 ó 159	15 Hz
			160 ó 169	16 Hz
	170 ó 179	17 Hz		
	180 ó 189	18 Hz		
	190 ó 199	19 Hz		
	200 ó 255	20 Hz		

HSV	Channel	Function	Value	Percent/Setting
	1	Hue	000 ó 255	0–100%
	2	Saturation	000 ó 255	0–100%
	3	Value	000 ó 255	0–100%

DMX Values (cont.)
PX16

Channel	Function	Value	Percent/Setting
1	Dimmer	000 ◊ 255	0–100%
2	Fine Dimmer	000 ◊ 255	0–100%
3	Pixel 1 Red	000 ◊ 255	0–100%
4	Pixel 1 Fine Red	000 ◊ 255	0–100%
5	Pixel 1 Green	000 ◊ 255	0–100%
6	Pixel 1 Fine Green	000 ◊ 255	0–100%
7	Pixel 1 Blue	000 ◊ 255	0–100%
8	Pixel 1 Fine Blue	000 ◊ 255	0–100%
9	Pixel 1 White	000 ◊ 255	0–100%
10	Pixel 1 Fine White	000 ◊ 255	0–100%
11	Pixel 1 Amber	000 ◊ 255	0–100%
12	Pixel 1 Fine Amber	000 ◊ 255	0–100%
13	Pixel 1 Virtual Color Wheel	000 ◊ 255	Refer to the Color Chart section for specific values
14	Pixel 2 Red	000 ◊ 255	0–100%
15	Pixel 2 Fine Red	000 ◊ 255	0–100%
16	Pixel 2 Green	000 ◊ 255	0–100%
17	Pixel 2 Fine Green	000 ◊ 255	0–100%
18	Pixel 2 Blue	000 ◊ 255	0–100%
19	Pixel 2 Fine Blue	000 ◊ 255	0–100%
20	Pixel 2 White	000 ◊ 255	0–100%
21	Pixel 2 Fine White	000 ◊ 255	0–100%
22	Pixel 2 Amber	000 ◊ 255	0–100%
23	Pixel 2 Fine Amber	000 ◊ 255	0–100%
24	Pixel 2 Virtual Color Wheel	000 ◊ 255	Refer to the Color Chart section for specific values

DMX Values (cont.)

PIX1	Channel	Function	Value	Percent/Setting
	1	Pixel 1 Red	000 ó 255	0–100%
	2	Pixel 1 Green	000 ó 255	0–100%
	3	Pixel 1 Blue	000 ó 255	0–100%
	4	Pixel 1 Virtual Color Wheel	000 ó 255	Refer to Color Chart section for specific values
	5	Pixel 2 Red	000 ó 255	0–100%
	6	Pixel 2 Green	000 ó 255	0–100%
	7	Pixel 2 Blue	000 ó 255	0–100%
	8	Pixel 2 Virtual Color Wheel	000 ó 255	Refer to Color Chart section for specific values

PIX3	Channel	Function	Value	Percent/Setting
	1	Pixel 1 Red	000 ó 255	0–100%
	2	Pixel 1 Green	000 ó 255	0–100%
	3	Pixel 1 Blue	000 ó 255	0–100%
	4	Pixel 1 White	000 ó 255	0–100%
	5	Pixel 1 Amber	000 ó 255	0–100%
	6	Pixel 1 Virtual Color Wheel	000 ó 255	Refer to Color Chart section for specific values
	7	Pixel 2 Red	000 ó 255	0–100%
	8	Pixel 2 Green	000 ó 255	0–100%
	9	Pixel 2 Blue	000 ó 255	0–100%
	10	Pixel 2 White	000 ó 255	0–100%
	11	Pixel 2 Amber	000 ó 255	0–100%
	12	Pixel 2 Virtual Color Wheel	000 ó 255	Refer to Color Chart section for specific values

OVATION C-640FC Sections for DMX Pixel Control

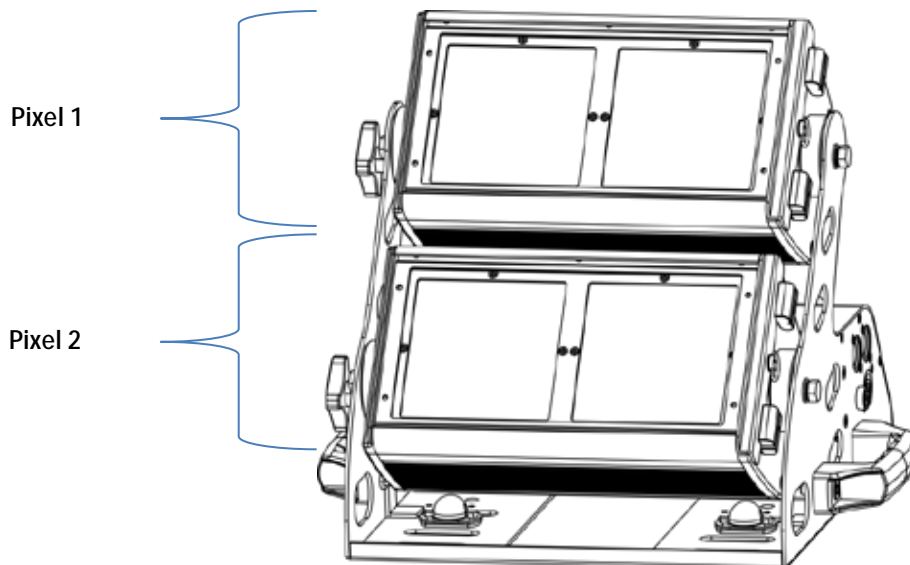

Virtual Color Wheel The OVATION C-640FC includes a new feature called the Virtual Color Wheel (VCW). This feature is available as a stand-alone control mode for manual use and as a control channel in each of the product’s DMX personalities. Over thirty pre-mixed colors based on popular gel colors from are available to call up for easier programming. When manually selecting the colors on the Virtual Color Wheel, the referenced gel number appears on the LED display for convenient selection and ease-of-use.

Color Chart

DMX Channel Value	Display Readout	Red Value	Green Value	Blue Value	White Value	Amber Value
000 ó 005	--	000	000	000	000	000
006 ó 013	C90Y	255	250	000	000	255
014 ó 021	R11	255	213	000	020	255
022 ó 028	R312	255	216	000	000	190
029 ó 035	R03	240	129	002	072	255
036 ó 043	R18	245	108	000	035	255
044 ó 051	R20	255	109	000	000	255
052 ó 059	R21	170	039	000	000	255
060 ó 067	R26	245	002	000	000	031
068 ó 075	R27	255	000	000	002	000
076 ó 083	R33	042	000	000	245	234
084 ó 091	R337	155	064	006	165	255
092 ó 099	R38	226	154	024	045	255
100 ó 107	R41	255	008	000	010	150
108 ó 115	R42	255	006	000	024	055
116 ó 121	R44	255	041	010	130	000
122 ó 130	R349	255	027	024	000	000
131 ó 138	R54	173	226	042	080	255
139 ó 146	R64	000	255	062	099	215
147 ó 154	R364	000	185	039	255	205
155 ó 162	R65	000	239	062	205	000
163 ó 170	R80	000	249	205	011	000
171 ó 178	R81	000	248	117	108	000
179 ó 186	R82	000	239	062	205	000
187 ó 194	R382	020	000	255	000	000
195 ó 202	R83	000	144	255	000	000
203 ó 210	R383	000	034	255	031	000
211 ó 218	R91	000	255	000	084	035
219 ó 226	R92	043	255	003	255	055
227 ó 234	R93	063	255	015	125	000
235 ó 242	R393	000	255	022	070	000
243 ó 250	R90	005	255	000	000	015
251 ó 255	--	000	000	000	000	000



The colors above are simulated renditions of the color output produced as compared to other similar incandescent products. Chauvet makes no guarantee of the color output accuracy.

DMX Personality Set the DMX personality as follows.

1. Go to the **PERS** main level.
 2. Select the desired personality (**TOUR**, **TR16**, **ARC.1**, **AR1.D**, **ARC.2**, **ARC.3**, **AR3.D**, **AR3.S**, **HSV**, **PIX1**, **PX16**, **PIX3**).
- See the **DMX Control** section for the highest starting address you can select for each personality.
 - Make sure that the starting addresses on the various products do not overlap due to the new personality setting.



DMX Control

DMX Control allows you to assign each product to a unique starting address on the DMX controller. All products with the same starting address will respond in unison.

1. Select a DMX personality.
2. Set the running mode:
 - Go to the **RUN** main level.
 - Select **DMX**.

Note: For information on the **SLAV** option, see [Master/Slave Mode](#).
3. Set the starting address:
 - Go to the **ADDR** main level.
 - Select the starting address **D.001–D.512**.

The highest recommended starting address for each DMX mode is as follows:



DMX Mode	DMX Address	DMX Mode	DMX Address	DMX Mode	DMX Address
TOUR	501	TR16	495	ARC.1	509
AR1.D	508	ARC.2	508	ARC.3	507
AR3.D	506	AR3.S	505	HSV	510
PIX1	505	PIX3	501	PX16	489

Loss of Signal Setting

This setting controls how the product responds when the DMX signal is lost.

1. Go to the **SET** main level.
2. Select the **DERR** programming level.
 - Select **BLAK** to turn off the LEDs when the signal is lost.
 - Select **SAVE** to use the last command programmed when the signal is lost.

Dimming Profiles Select the dimming profile of the OVATION C-640FC by selecting the **DIMX** programming level.

1. Go to the **SET** main level.
2. Select the **DIMX** programming level.
3. Select a dimming program **DIM1–DIM4** (fast to slow) or **OFF** (linear output).

Control Panel Lock This setting enables you to activate or deactivate the control panel lock, which keeps non-authorized personnel from changing the product's settings.

1. Go to the **SET** main level.
2. To to the **KEY** programming level.
3. Select either **ON** (activate) or **OFF** (deactivate).



When the control panel lock is activated, after 30 seconds of control panel inactivity or after turning on the product, the product will prompt you to enter the passcode.

Passcode

After being prompted to enter the passcode:

- Press **<UP>**, **<DOWN>**, **<UP>**, **<DOWN>**, **<ENTER>**.

Note: Asterisks (*) appear on the display when entering the passcode.



Passcode can not be changed.

Menu Access Lock

This setting enables you to activate or deactivate the menu access lock. Activating the menu access lock prevents non-authorized personnel from making any changes to the programming levels under the **SET** main level.

1. Go to the **SET** main level.
2. Go to the **SLCK** programming level.
3. Select either **ON** (activate) or **OFF** (deactivate).



When the menu access lock is activated, in order to access the SET programming levels, the product will prompt you to enter the passcode. Enter the passcode as described in [Passcode](#).

Setting Color Balance

Color balance settings allow you to select the output as follows.

1. Go to the **SET** main level.
2. Go to the **COLR** programming level.
3. Select **OFF** (maximum output), **RGBW** (balanced white), or **UC** (universal color balance).

Strobe Options for TOUR and TR16

The strobe behavior displayed in the **TOUR** and **TR16** personalities is set to either classic or special. Classic strobe allows DMX control to select 1 to 20 Hz, while special strobe exhibits different strobe behaviors according to the DMX value selected (for details, see [TOUR](#) or [TR16](#) DMX Values). To select the strobe option, follow the instructions below.

1. Go to the **SET** main level.
2. Go to the **STRB** programming level.
3. Select either **SPEC** (special) or **CLAS** (classic).

Color Macros and White Settings

These settings allow you to select and edit the temperature of the white colors used in the macros when in Channel 8 of the **TOUR** mode or Channel 14 of the **TR16** mode.

1. Go to the **CAL** main level.
2. Enter the passcode as described in [Passcode](#).
3. Go to **CAL1**.
4. Select a white color (**WH.01–WH.11**).
5. Select a color **RED** (red), **GREN** (green), **BLUE** (blue), **WHIT** (white), or **AMBE** (amber).
6. Select a color value (**X.000–X.255**).
7. Repeat for the other colors.

White Calibration

This setting allows you to select the white color shown by the OVATION C-640FC when the color setting is **RGBW** and the DMX controller's red, green, and blue faders are set to **255**.

1. Go to the **CAL** main level.
2. Enter the passcode as described in [Passcode](#).
3. Go to **CAL2**.
4. Select a color **RED** (red), **GREN** (green), or **BLUE** (blue).
5. Select a color value (**X.000–X.255**).
6. Repeat for the other colors.



When setting the white calibration (CAL2), you will only be able to define the red, green, and blue values.

Resetting the CAL Settings

To return the settings in **CAL1** and **CAL2** of the OVATION C-640FC to the factory defaults, follow the instructions below.

1. Go to the **CAL** main level.
2. Enter the passcode as described in [Passcode](#).
3. Go to the **CALR** programming level and then the display becomes blank.
4. Enter the passcode as described in [Passcode](#).

Configuration (Standalone) Set the product in one of the standalone modes to control without a DMX controller.

- Connect the product to a suitable power outlet.



Never connect a product that is operating in any standalone mode (static, auto, or customizable programs) to a DMX string connected to a DMX controller. Products in standalone mode may transmit DMX signals that could interfere with the DMX signals from the controller.

Static Mode To create a custom static color and select a strobe frequency, do the following:

1. Go to the **STAT** main level.
2. Go to the **RED** (red), **GREN** (green), **BLUE** (blue), **WHIT** (white), **AMBE** (amber), **STRB** (strobe frequency) programming levels.
3. Select the desired value for the programming levels as follows.
 - **X.000–X.255** (0–100%) for each color
 - **S.000–S.020** (0–20 Hz) for strobe frequency

Auto and Customizable Programs To enable the auto and customizable programs, follow the instructions below:

1. Go to the **AUTO** main level.
2. Select an auto program **AT.01–AT.10** or a customizable program **PR.01–PR.10**.
3. With the auto programs, also select the auto program speed **P.000–P.255**.



You cannot edit any of the auto programs (AT.01–AT.10); however, you can edit the custom programs (PR.01–PR.10). See [Edit Custom Programs](#) for details.

Selecting from the Virtual Color Wheel The OVATION C-640FC offers over thirty pre-mixed colors based on gel colors. To select a gel color, do the following.

1. Go to the **VCW** main level.
2. Select the desired color (**C90Y, R11, R312, R03, R18, R20, R21, R26, R27, R33, R337, R38, R41, R42, R44, R349, R54, R64, R364, R65, R80, R81, R82, R382, R83, R383, R91, R92, R93, R393, or R90**).
See the [Color Chart](#) section for details on specific values.

Edit Custom Programs This setting allows the programming of up to 30 scenes for each of the 10 customizable programs, including colors and effects.

1. Go to the **EDIT** main level.
2. Select the desired custom program **PR.01–PR.10**.
3. Select the desired scene **SC.01–SC.30**.
4. Go to the **RED** (red), **GREN** (green), **BLUE** (blue), **WHIT** (white), **AMBE** (amber), **STRB** (strobe frequency), **TIME** (step duration), and **FADE** (fade duration) programming levels.
5. Select the desired value for the programming levels as follows.
 - **X.000–X.255** (0–100%) for each color
 - **S.000–S.020** (0–20 Hz) for strobe frequency
 - **T.000–T.255** (slow to fast) to define the step duration
 - **F.000–F.255** (slow to fast) to define the fade duration
6. Repeat for the other colors or effects.
7. Return to the scene programming level (**SC.01–SC.30**).
8. Repeat the setting of colors and effects for the other scenes.



Do not disconnect the product from power before completing the editing process. Make sure to complete all steps when editing custom programs; otherwise, the OVATION C-640FC may lose any incomplete custom programming.

Reset To reset the OVATION C-640FC to the factory default settings, follow the instructions below.

1. Go to the **SET** main level.
2. Select the **REST** programming level and then the display becomes blank.
3. Enter the passcode as described in [Passcode](#). After successfully entering the passcode, **REST** blinks on the display during the reset process.
4. **OK** appears on the display when finished.

Master/Slave Mode

The Master/Slave mode allows a single OVATION C-640FC (the “master”) to control the actions of one or more OVATION C-640FC units (the “slaves”) without the need of a DMX controller. The master will be set to Master mode (**MAST**) and operate in a stand-alone mode, while the slaves will be set to operate in Slave mode (**SLAV**). Once set and connected, the slaves will operate in unison with the master.

Configure the units as indicated below.

The Slaves:

1. Go to the **RUN** main level.
2. Select **SLAV**.
3. Connect the DMX input of the first slave to the DMX output of the master.
4. Connect the DMX input of the subsequent slaves to the DMX output of the previous slave.
5. Finish setting and connecting all the slaves.

The Master:

1. Go to the **SET** main level.
2. Select the **MCON** programming level.
3. Select **MAST**.
 - Note:** If you select **SELF**, no DMX signals are sent to the slaves.
4. Set the master to operate in Static mode, an auto program or a customizable program.
5. Make the master the first product in the DMX daisy chain and the slaves will operate in unison with the master.



- **Do not connect a DMX controller to the products configured for slave operation. The DMX controller may interfere with signals from the master.**
- **Do not connect more than 31 slaves to the master.**

Program Upload

This option allows you to copy the custom programs of one OVATION C-640FC onto other OVATION C-640FCs by using the Master/Slave mode.

1. Configure and connect the products in a Master/Slave arrangement, where the master product has the custom programs you want to transfer to the slave products.
2. From the master product, go to the **SET** main level.
3. Go to the **UPLD** programming level and then the display becomes blank.
4. Enter the passcode as described in [Passcode](#).
5. When **SEND** shows on the display, press **<ENTER>** to start the upload.
6. Wait for the upload process to finish. **END** will appear on the display when finished.

The Master/Slave products will provide the status of the process by lighting up as follows:



- **Yellow indicates that the upload process is running.**
- **Green indicates that the upload process completed successfully.**
- **Red indicates that the upload process failed due to an error. Recheck all cable connections and restart the process. If the issue persists, contact Chauvet Technical Support.**



DO NOT upload the data from an OVATION C-640FC to a different product. The other product may become inoperable.

5. Technical Information

Product Maintenance

Dust build-up reduces light output performance and can cause overheating. This can lead to reduction of the light source's life and mechanical wear. To maintain optimum performance and minimize wear, clean this product at least twice a month. However, usage and environmental conditions contribute to increased cleaning frequency.

To clean your product, follow the instructions below.

1. Unplug the product from power.
2. Wait until the product is at room temperature.
3. Use a vacuum (or dry compressed air) and a soft brush to remove dust collected on the external vents and components.
4. Clean all external surfaces with a mild solution of non-ammonia glass cleaner or isopropyl alcohol.
5. Apply the solution directly to a soft, lint-free cotton cloth or a lens cleaning tissue.
6. Wipe any dirt or grime to the outside edges of the lens surface.
7. Gently polish the lens surfaces until they are free of haze and lint.



Always dry the external surfaces thoroughly and carefully after cleaning them.



Do not spin the fan using compressed air because you could damage the product.

Technical Specifications

Dimensions and Weight

Length	Width	Height	Weight
15.3 in (390 mm)	12.2 in (310 mm)	11.7 in (298 mm)	22 lb (9.98 kg)

Note: Dimensions in inches rounded to the nearest decimal digit.

Power

Power Supply Type	Range	Voltage Selection
Switching (internal)	100 to 240 VAC, 50/60 Hz	Auto-ranging

Parameter	120 V, 60 Hz	230 V, 50 Hz
Consumption	175 W	173 W
Operating current	1.44 A	0.76 A
Power linking current (units)	13.6 A (9 units)	13.6 A (18 units)
Fuse	F 5 A, 250 V	F 5 A, 250 V

Power I/O	U.S./Worldwide	Europe
Power input connector	Neutrik powerCON A	Neutrik powerCON A
Power output connector	Neutrik powerCON B	Neutrik powerCON B
Power cord plug	Edison (U.S.)	Local plug

Light Source

Type	Power	Lifespan
LED	3 to 5 W	50,000 hours

Color	Quantity	Current
Red	16	850 mA
Green	16	850 mA
Blue	16	850 mA
White	8	850 mA
Amber	8	850 mA

Photometrics

Parameter	
Illuminance @ 5 m	141 lx
Beam angle	35°
Field angle	65°

Thermal

Max. External Temperature	Cooling System
113 °F (45 °C)	Fan-Assisted Convection

DMX

I/O Connectors	Connector Type	Channel Range
3- and 5-pin XLR	Sockets	3, 4, 5, 6, 7, 8, 12 or 18

Ordering

Product Name	Item Code	UPC Number
OVATION C-640FC	01030723	781462210717



UL 1573
CSA C22.2 No. 166
E113093



Returns You must send the product prepaid, in the original box, and with the original packing and accessories. Chauvet will not issue call tags.

Call Chauvet and request a Return Merchandise Authorization (RMA) number before shipping the product. Be prepared to provide the model number, serial number, and a brief description of the cause(s) for the return.

Clearly label the package with an RMA number. Chauvet will refuse any product returned without an RMA number.



DO NOT write the RMA number directly on the box. Instead, write it on a properly affixed label.

Once you have received the RMA number, include the following information on a piece of paper inside the box:

- Your name
- Your address
- Your phone number
- RMA number
- A brief description of the problem(s)

Be sure to pack the product properly. Any shipping damage resulting from inadequate packaging will be the customer's responsibility. FedEx packing or double-boxing is recommended.



Chauvet reserves the right to use its own discretion to repair or replace returned product(s).

Contact Us

WORLD HEADQUARTERS - Chauvet

General Information

Address: 5200 NW 108th Avenue
Sunrise, FL 33351
Voice: (954) 577-4455
Fax: (954) 929-5560
Toll free: (800) 762-1084

Technical Support

Voice: (954) 577-4455 (Press 4)
Fax: (954) 756-8015
Email: tech@chauvetlighting.com

World Wide Web www.chauvetlighting.com

UNITED KINGDOM AND IRELAND - Chauvet Europe Ltd.

General Information

Address: Unit 1C
Brookhill Road Industrial Estate
Pinxton, Nottingham, UK
NG16 6NT

Voice: +44 (0)1773 511115
Fax: +44 (0)1773 511110

Technical Support

Email: uktech@chauvetlighting.com

World Wide Web www.chauvetlighting.co.uk

MEXICO - Chauvet Mexico

General Information

Address: Av. Santa Ana 30
Parque Industrial Lerma
Lerma, Mexico C.P. 52000

Voice: +52 (728) 285-5000

Technical Support

Email: servicio@chauvet.com.mx

World Wide Web www.chauvet.com.mx

CHAUVET EUROPE - Chauvet Europe BVBA

General Information

Address: Stokstraat 18
9770 Kruishoutem
Belgium

Voice: +32 9 388 93 97

Technical Support

Email: Eutech@chauvetlighting.eu

World Wide Web www.chauvetlighting.eu

Outside the U.S., United Kingdom, Ireland, Mexico, or Benelux contact the dealer of record. Follow their instructions to request support or to return a product. Visit our website for contact details.